

# MODEL WCU-CHB (Large)

**PACKAGED WATER COOLED CHILLER**

**45.7 - 197.1 TR**

**160.6 - 693 KW**

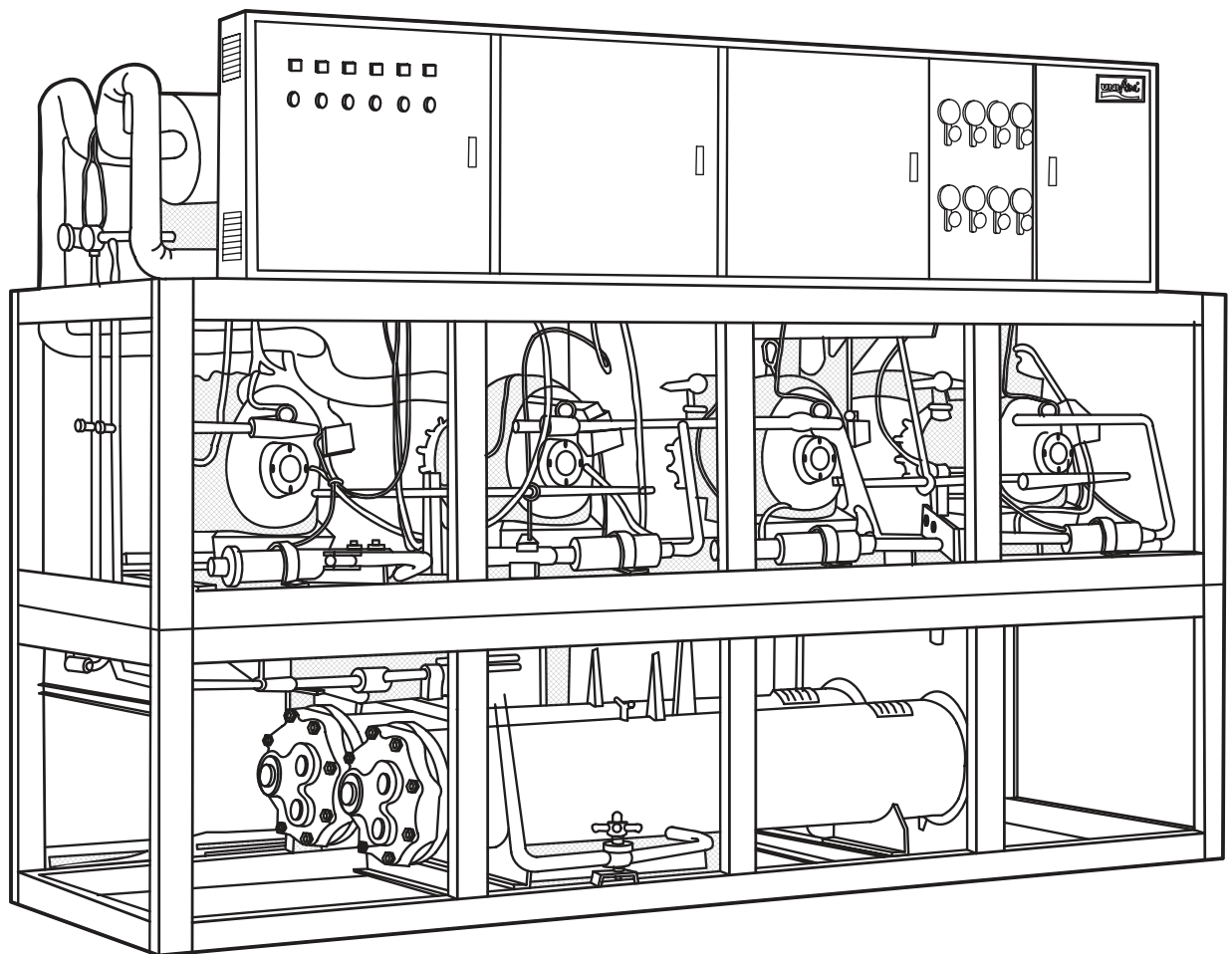

# DIMENSIONAL DRAWINGS

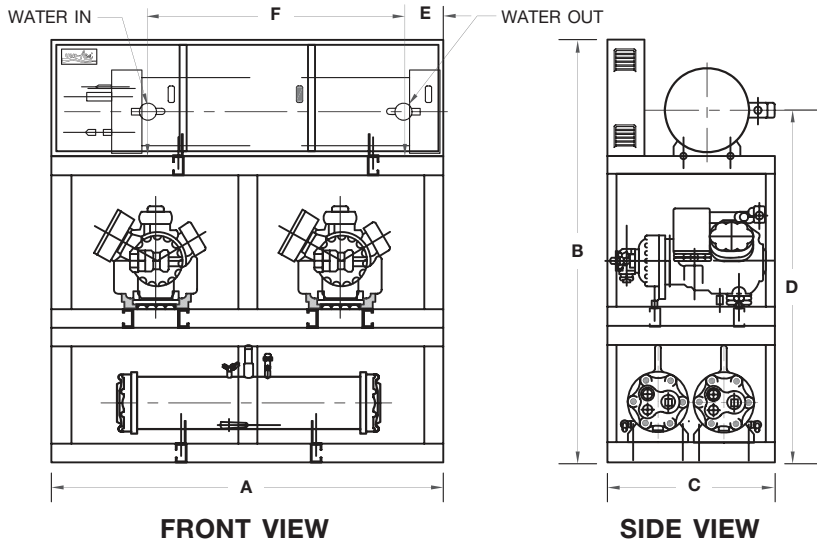

| MODEL   | DIMENSION MODEL : WCU-CHB |       |         |
|---------|---------------------------|-------|---------|
|         | 050                       | 060   | 070-080 |
| A (mm.) | 2,032                     | 2,286 | 2,746   |
| B (mm.) | 2,121                     | 2,121 | 2,121   |
| C (mm.) | 890                       | 890   | 890     |
| D (mm.) | 1,746                     | 1,746 | 1,746   |
| E (mm.) | 198                       | 198   | 232     |
| F (mm.) | 1,334                     | 1,601 | 2,032   |

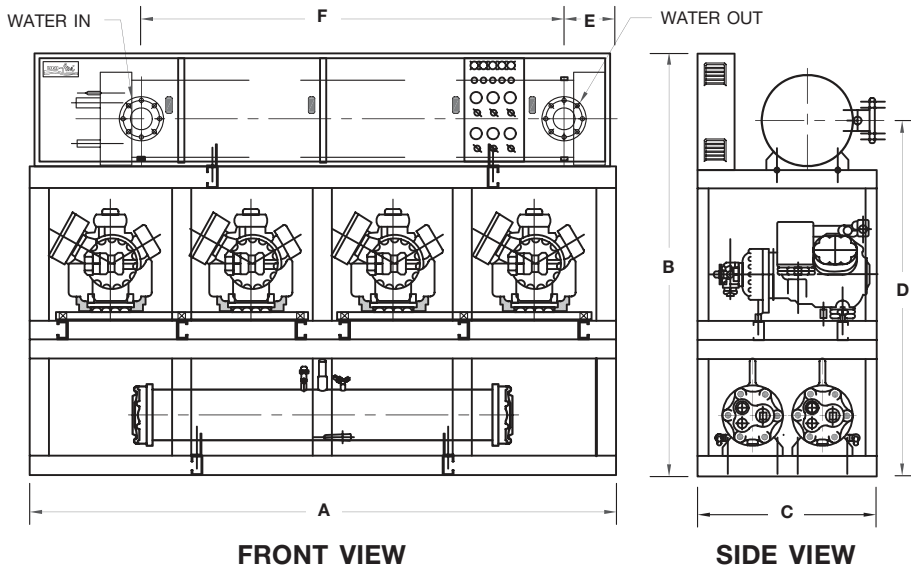

| MODEL   | DIMENSION MODEL : WCU-CHB |       |     |     |
|---------|---------------------------|-------|-----|-----|
|         | 100                       | 120   | 140 | 160 |
| A (mm.) | 3,048                     | 3,548 |     |     |
| B (mm.) | 2,221                     | 2,321 |     |     |
| C (mm.) | 940                       | 1,120 |     |     |
| D (mm.) | 1,865                     | 1,990 |     |     |
| E (mm.) | 256                       | 306   |     |     |
| F (mm.) | 2,210                     | 2,718 |     |     |

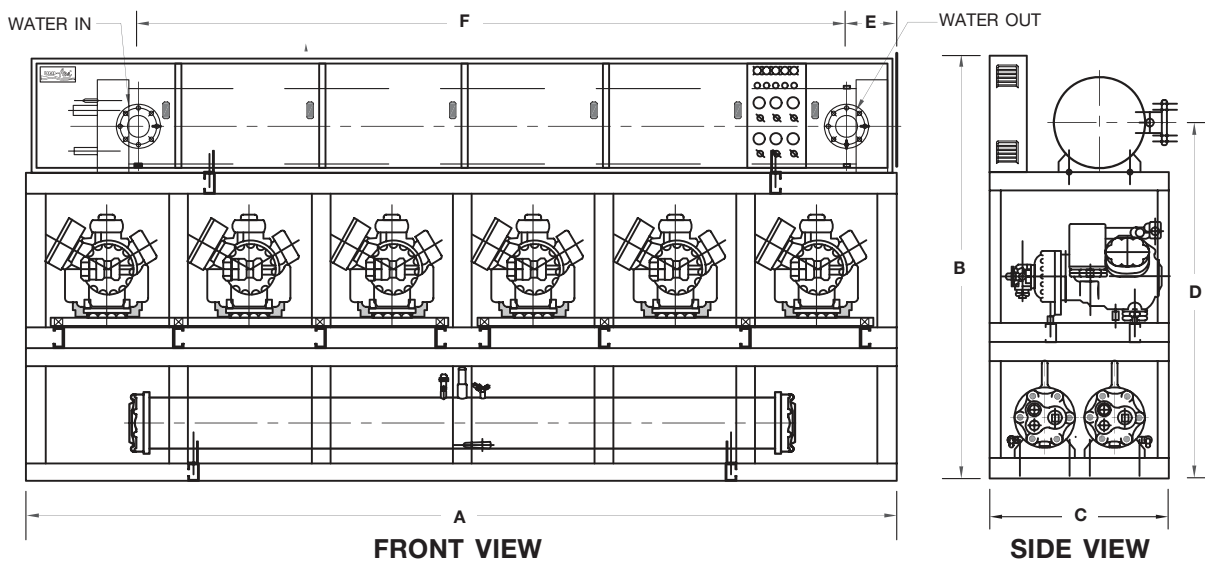

| MODEL     | DIMENSION MODEL : WCU-CHB |       |       |       |       |       |
|-----------|---------------------------|-------|-------|-------|-------|-------|
|           | A                         | B     | C     | D     | E     | F     |
| 180 (mm.) | 4,522                     | 2,361 | 1,200 | 2,266 | 1,054 | 2,016 |
| 200 (mm.) | 4,522                     | 2,361 | 1,100 | 2,266 | 902   | 2,016 |
| 240 (mm.) | 4,522                     | 2,361 | 1,100 | 2,266 | 927   | 2,092 |

# PHYSICAL DATA & ELECTRICAL DATA

| SPECIFICATION MODEL : WCU-CHB (Comp. SCREW) |                    |   |       |             |       |       |       |         |             |        |         |        |           |      |
|---|--------------------|---|-------|-------------|-------|-------|-------|---------|-------------|--------|---------|--------|-----------|------|
| MODEL WCU-CHB<br>(2 CIRCUITS)               |                    | 050   | 060   | 070         | 080   | 100   | 120   | 140     | 160         | 180    | 210     | 240    |           |      |
| Nominal Cooling capacity*                   | MBH                | 550   | 600   | 700         | 790   | 1,100 | 1,200 | 1,400   | 1,580       | 1,800  | 2,100   | 2,400  |           |      |
| Power Consumption                           | kw                 | 40.42   | 45.72 | 54.75       | 63.78 | 80.84 | 91.44 | 109.50  | 127.56      | 137.16 | 164.25  | 191.34 |           |      |
| Compressor                                  | Type               | Semi-Hermetic   |       |             |       |       |       |         |             |        |         |        |           |      |
|   | HP                 | 25  | 30    | 30 : 40     | 40    | 25    | 30    | 30 : 40 | 40          | 30     | 30 : 40 | 40     |           |      |
|   | Qty./Unit          | 2   |       | 1 : 1       | 2     | 4     |       | 2 : 2   | 4           | 6      | 3 : 3   |        | 6         |      |
| Water Cooled Condenser                      |                    |   |       |             |       |       |       |         |             |        |         |        |           |      |
| Fouling Factor                              |                    | 0.0005 (0.000046) Ft <sup>2</sup> .h.F./BTU (m <sup>2</sup> .h.F./BTU)                  |       |             |       |       |       |         |             |        |         |        |           |      |
| Water Flow Rate                             | GPM                | 146.7   | 160.0 | 186.7       | 210.7 | 293.3 | 320.0 | 373.3   | 421.3       | 480.0  | 560.0   | 640.0  |           |      |
| Entering Water Temp.                        | °F                 | 90  |       |             |       |       |       |         |             |        |         |        |           |      |
| Leaving Water Temp.                         | °F                 | 100   |       |             |       |       |       |         |             |        |         |        |           |      |
| Water Pressure Drop                         | Ft.WG              | 13.0  | 16.6  |             | 6.0   | 10.5  | 8.0   | 6.5     |             |        | 8.5     | 6.5    |           |      |
| No. of Water Passer                         |                    | 4   | 2     |             |       |       |       |         |             |        |         |        |           |      |
| Water Connection (In..Out)                  | inch               | 2-1/2   |       | 2-1/2..3    |       |       | 3..4  |         |             |        |         |        |           |      |
| Qty./Unit                                   |                    | 2   |       |             |       |       |       |         |             |        |         |        |           |      |
| Water Chiller                               |                    | FOULING FACTOR 0.00005 Ft . h. <sup>2</sup> F. / BTU (0.000046 <sup>2</sup> m .h.F/BTU) |       |             |       |       |       |         |             |        |         |        |           |      |
| No. Of Circuits                             |                    | 2   |       |             |       |       |       |         |             |        |         |        |           |      |
| Chiller Water Flow Rate                     | GPM                | 110.0   | 120.0 | 140.0       | 158.0 | 220.0 | 240.0 | 280.0   | 316.0       | 360.0  | 420.0   | 480.0  |           |      |
| Chiller Water Temp. In/Out                  | °F                 | 55 / 45   |       |             |       |       |       |         |             |        |         |        |           |      |
| Chiller Water Pressure Drop                 | Ft.WG              | 3.66  | 2.72  | 4.64        | 5.69  | 8.59  | 4.83  | 5.83    | 6.89        | 7.57   | 11.13   | 8.69   |           |      |
| Water Connection In/Out                     | in                 | 3   |       | 4           |       |       | 5     |         |             | 6      |         |        |           |      |
| Qty./Unit                                   |                    | 1   |       |             |       |       |       |         |             |        |         |        |           |      |
| Refrigerant                                 | Type               | R-22  |       |             |       |       |       |         |             |        |         |        |           |      |
|   | Charge             | Holding   |       |             |       |       |       |         |             |        |         |        |           |      |
| Compressor (Each)                           | V / PH / Hz        | 380 / 3 / 50  |       |             |       |       |       |         |             |        |         |        |           |      |
|   | Power Input (Watt) | 20.21   | 22.86 | 22.86:31.89 |       | 31.89 | 20.21 | 22.86   | 22.86:31.89 |        | 67.9    | 44.9   | 48.7:67.9 | 67.9 |
|   | RLA. (Amp.)        | 44.9  | 48.7  | 48.7:67.9   |       | 67.9  | 44.9  | 48.7    | 48.7:67.9   |        | 67.9    | 44.9   | 48.7:67.9 | 67.9 |
|   | LRA. (Amp.)        | 134   | 162   | 162:207     |       | 207   | 134   | 162     | 162:207     |        | 207     | 134    | 162:207   | 207  |
| Weight Operation                            | Kgs.               | 1,389   | 1,470 | 1,704       | 1,758 | 2,284 | 2,658 | 2,857   | 3,071       | 3,473  | 3,783   | 4,287  |           |      |

MBH = 1,000 BTUH

\* Nominal Cooling Capacity Bssed on 38 °F Suction Temp. and 95 °F Entering Water Temp

Liquid Subcooled 15 °F

FOR SI. UNIT, COOLING CAPACITY (kW) =  $\frac{\text{MBH} \times 1000}{3412}$

# PACKAGED WATER COOLED CHILLER STANDARD ACCESSORIES

## REFRIGERATION PARTS

- THERMOSTATIC EXPANSION VALVES
- SOLENOID VALES
- SIGHT GLASSES
- FILTER DRIERS
- SERVICE & SHUT OFF VALVES
- CHECK VALVES FOR PARALLEL CIRCUIT COMPRESSORS

## ELECTRICAL PARTS

- MAGNETIC CONTACTOR W/OVERLOAD FOR MOTOR COMPRESSOR
- TIMER DELAY RELAY DEVICES
- OIP PRESSURE SWITCH
- CRANKCASE HEATERS
- TEMPERATURE CONTROL DEVICE
- FREEZESTAT

## REMARK

- TEMPERATURE CONTROL
- 2 STAGES FOR UNIT THAT HAS 2 COMPRESSORS
- 4 STAGES FOR UNIT THAT HAS 2 COMPRESSORS

\*\*Eurovent certified for model DAHH only.



UNIAIRE CORPORATION CO., LTD.

69 Moo 3 Kingkeaw Rd., Rachatewa District, Bangplee,  
Samutprakarn 10540 Thailand

Email.localsale@uni-aire.com | Email.export@uni-aire.com

Tel.+662-312-4500, www.uni-aire.com

@uni-aire Uni-Aire Whatsapp.+666-2312-3069