

# MODEL WCU-CHB (Middle)

## PACKAGED WATER COOLED CHILLER

6.8 - 34 TR

24 - 120 KW

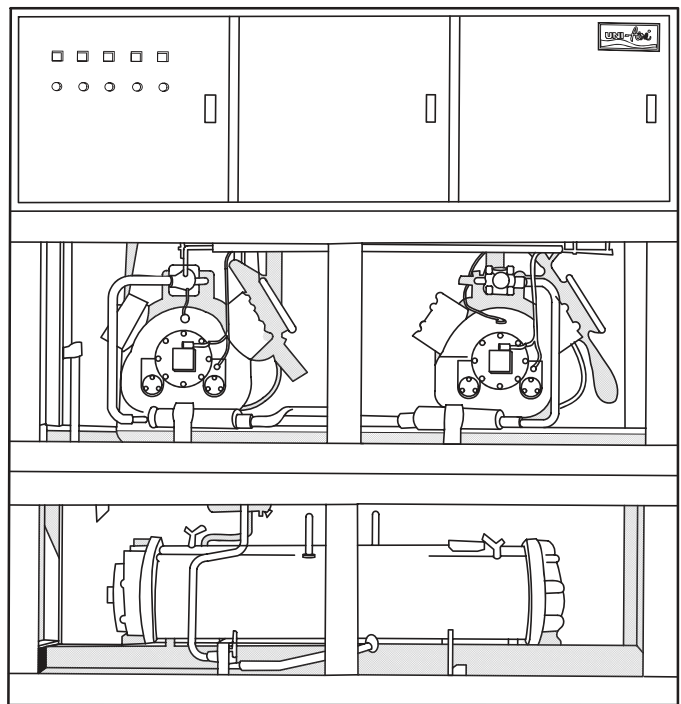
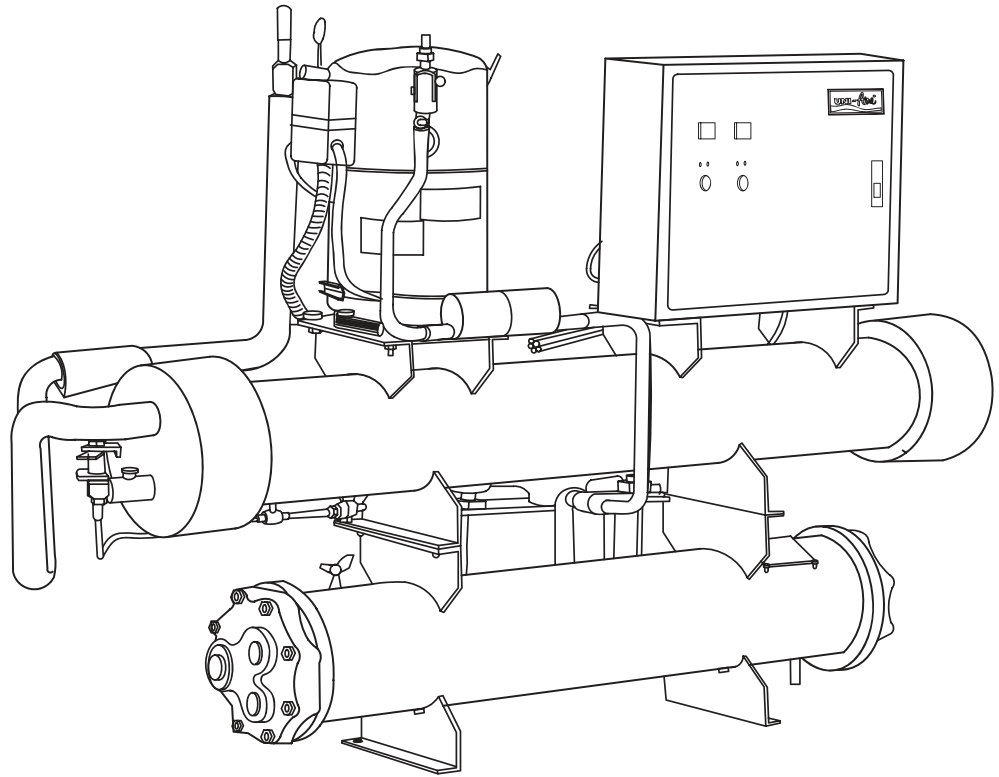

Air Conditioning Experts

**SPECIFICATION MODEL : WCU-CHB**

MODEL	WCU-CHB	007H	009H	010H	012H	015H (2 CIR)	018H (2 CIR)	020H (2 CIR)	025H (2 CIR)
NOMINAL COOLING CAPCTY	(MBH)	75	90	105	125	152	180	210	250
NO. OF CIRCUITS		1 CIRCUIT				2 CIRCUIT			
COMPRESSOR	Type	HERMETIC							
	HP.	7.5	9	10	12	7.5	9	10	12
	Qty./Unit	1				2			
<b>WATER COOLED CONDENSER</b>									
Qty./Unit		1				2			
Water Flow Rate	(GPM)	20.00	24.00	28.00	33.33	40.53	48.00	56.00	66.67
Entering Water Temp.	°F	90							
Leaving Water Temp.	°F	100							
Water Pressure Drop	(Ft.WG)	11.5	10.2	14.6	9.5	2x11.5	2x10.2	2x14.9	2x9.5
No. of Water Passer		4							
Water Connection In/Out	(in)	1	1-1/2		2x1		2x1-1/2		
<b>WATER CHILLER</b>									
Qty./Unit		1							
No. of Circuits		1				2			
Chilled Water Flow Rate	(GPM)	15.00	18.00	21.00	25.00	30.40	36.00	42.00	50.00
Chilled Water Temp. In/Out	°F	55/45							
Chilled Water Pressure Drop	(Ft.WG)	1.4	1.78	2.76	3.92	1.95	0.96	1.19	2.07
Water Connection In/Out	(in)	1-1/4				1-1/2	2		
REFRIGERANT	Type	R-22							
	Charge	HOLDING							
COMPRESSOR (Each)	V/PH/HZ	380/3/50							
	Power Input (Watt)	6.54	7.82	8.95	10.8	6.54	7.82	8.95	10.8
	RLA. (Amp.)	12.1	14.3	20.7	22.9	12.1	14.3	20.7	22.9
	LRA. (Amp.)	98.00	130.00		145.00	98.00	130.00		145.00
WEIGHT	Operation (Kgs.)	230		268	310	593	602	656	780

Note : -

RLA = Rated Load Amp.

LRA = Locked Rotor Amp.

▲ MBH = 1,000 BTUH

\* Nominal Cooling Capacity Based on 38°F Suction Temp. Liquid Subcooled 15°F

Fouling Factor 0.0005 Ft<sup>2</sup> .h.F/BTU in Chiller and Condenser

FOR SI. UNIT, COOLING CAPACITY (KW) =  $\frac{MBH \times 1000}{3412}$

3412

**STANDARD ACCESSORIES**

**REFRIGERATION PARTS**

- THERMOSTATIC EXPANSION VALVE
- SIGHT GLASS
- FILTER DRIER
- SERVICE AND SHUT OFF VALVES

**ELECTRICAL PARTS**

- MAGNETIC CONTACTOR W/OVERLOAD FOR MOTOR COMPRESSOR
- TIME DELAY RELAY DEVICE
- HIGH-LOW PRESSURE SWITCHES
- TEMPERATURE CONTROL (2 STAGES FOR 2 CIRCUITS)
- FREEZESTAT

SPECIFICATION MODEL : WCU-CHB								
MODEL	WCU-CHB	015S	020S	025S	030S	040S	030S	040S
							(2 CIR)	(2 CIR)
NOMINAL COOLING CAPCTY (MBH)		160	210	275	300	400	320	420
NO. OF CIRCUITS		1 CIRCUIT					2 CIRCUIT	
COMPRESSOR	Type	SEMI-HERMETIC						
	HP.	15	20	25	30	40	15	20
	Qty./Unit	1					2	
WATER COOLED CONDENSER								
Qty./Unit		1					2	
Water Flow Rate (GPM)		42.67	56.00	73.33	80.00	106.67	85.33	112.00
Entering Water Temp. °F		90						
Leaving Water Temp. °F		100						
Water Pressure Drop (Ft.WG)		15.68	18.00	17.63	18.22	5.76	15.68	18.00
No. of Water Passer		4				2	4	
Water Connection In/Out (in)		1-1/2				2x1-1/2,1x3	1-1/2	
WATER CHILLER								
Qty./Unit		1						
No. of Circuits		1					2	
Chilled Water Flow Rate (GPM)		32.00	42.00	55.00	60.00	80.00	64.00	84.00
Chilled Water Temp. In/Out °F		55/45						
Chilled Water Pressure Drop (Ft.WG)		1.81	1.11	2.31	7.05	4.22	7.05	4.22
Water ConnectiIn/Out (in)		1-1/2	2		2-1/2	3	2-1/2	3
REFRIGERANT	Type	R-22						
	Charge	HOLDING						
COMPRESSOR (Each)	V/PH/HZ	380/3/50						
	Power Input (Watt)	11.65	15.2	20.21	22.86	31.89	11.65	15.2
	RLA. (Amp.)	48.6	33.3	44.9	48.7	67.9	48.7	67.9
	LRA. (Amp.)	120	104	134	162	207	162	207
WEIGHT Operation (Kgs.)		425	510	814	852	1,013	987	1,197

Note : -

RLA = Rated Load Amp.

LRA = Locked Rotor Amp.

▲ MBH = 1,000 BTUH

\* Nominal Cooling Capacity Based on 38 °F Suction Temp. Liquid Subcooled 15 °F

Fouling Factor 0.0005 Ft<sup>2</sup> .h.F/BTU in Chiller and Condenser

#### STANDARD ACCESSORIES

##### REFRIGERATION PARTS

- THERMOSTATIC EXPANSION VALVE
- SOLENOID VALVE
- SIGHT GLASS
- FILTER DRIER
- SERVICE VALVES

\*\* OPTIONAL PARTS

##### ELECTRICAL PARTS

- MAGNETIC CONTACTOR W/OVERLOAD FOR MOTOR
- COMPRESSOR
- TIME DELAY RELAY DEVICE
- HIGH-LOW PRESSURE SWITCHES
- CRANKCASE HEATERS\*\*
- TEMPERATURE CONTROL (2 STAGES FOR 2 CIRCUITS)
- FREEZESTAT

SPECIFICATIONS SUBJECT TO CHANGE WITHOUT NOTICE

# DIMENSIONAL DRAWINGS

## PACKAGED WATER COOLED CHILLER

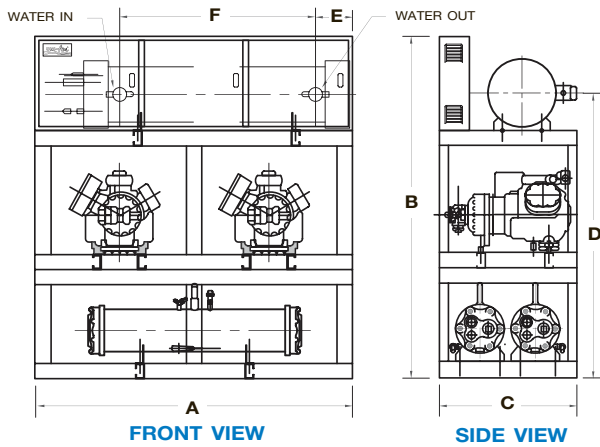
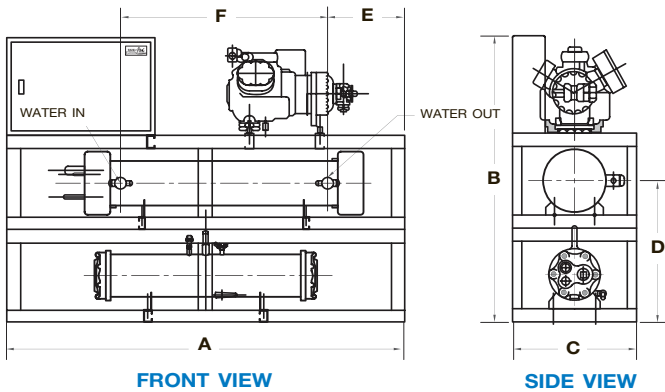
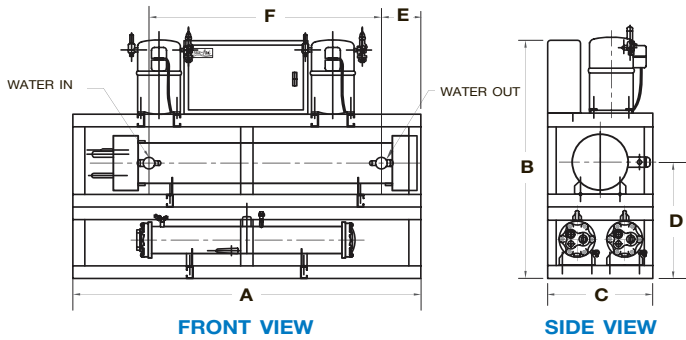
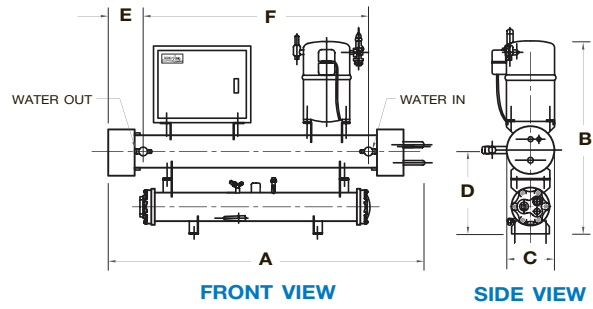
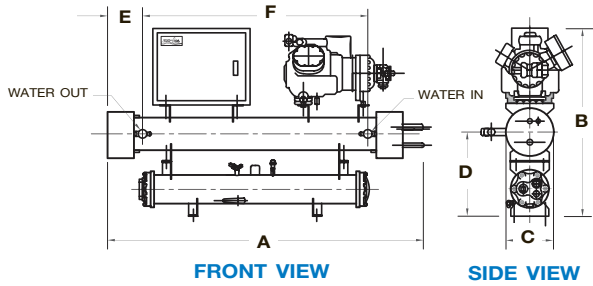

MODEL	DIMENSIONAL MODEL : WCU-CHB					
	A	B	C	D	E	F
WCU-CHB-007-009 H	1,528	1,070	279	449	167	1,067
WCU-CHB-010 H	1,833	1,110	279	475	167	1,372
WCU-CHB-012 H	1,833	1,110	279	475	167	1,372

MODEL	DIMENSIONAL MODEL : WCU-CHB					
	A	B	C	D	E	F
WCU-CHB-015 H (2 Cir.)	1,928	1,630	650	764	522	1,206
WCU-CHB-018 H (2 Cir.)	2,133	1,615	650	829	200	1,372
WCU-CHB-020 H (2 Cir.)	2,133	1,615	650	829	200	1,372
WCU-CHB-025 H (2 Cir.)	2,438	1,733	762	884	200	1,803

MODEL	DIMENSIONAL MODEL : WCU-CHB					
	A	B	C	D	E	F
WCU-CHB-015 S	2,500	1,940	762	947	200	1,803
WCU-CHB-020 S	2,000	1,910	762	960	219	1,346
WCU-CHB-025 S	2,300	1,910	762	960	214	1,639
WCU-CHB-030 S	1,950	1,657	650	884	219	1,206
WCU-CHB-040 S	2,438	1,808	762	934	200	1,498

MODEL	DIMENSIONAL MODEL : WCU-CHB					
	A	B	C	D	E	F
WCU-CHB-030 S (2 Cir.)	2,000	1,920	890	1,520	198	1,346
WCU-CHB-040 S (2 Cir.)	2,286	2,021	890	1,621	214	1,639

\*\*Eurovent certified for model DAHH only.



UNIAIRE CORPORATION CO., LTD.

69 Moo 3 Kingkeaw Rd., Rachatewa District, Bangplee,

Samutprakarn 10540 Thailand

Email.local@uni-aire.com | Email.export@uni-aire.com

Tel.+662-312-4500, www.uni-aire.com

LINE @uni-aire Facebook Uni-Aire WhatsApp.+666-2312-3069