

MODEL VACU-CHB (Comp. SCREW)

PACKAGED AIR COOLED CHILLER

39.2 - 167.7 TR

137.7 – 589.7 kW



UNI-Aire[®]
Air Conditioning Experts

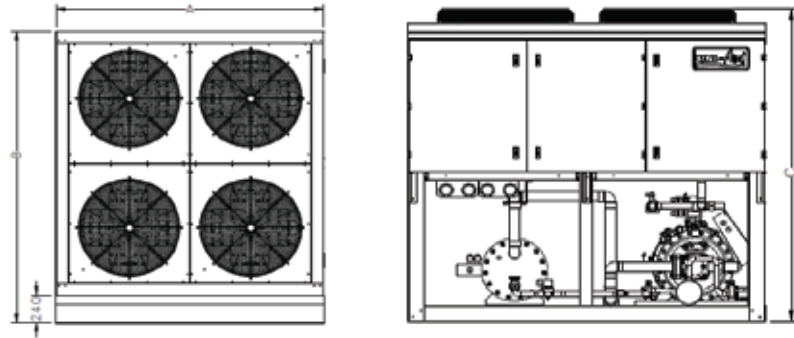

	050,060	070,080	100,120	150	180	200	240
A	2270	3385	4450	5615	6730	7845	8960
B	2030						
C	2200						

Unit: mm.(Milimeter)

Smart Control

LCD Display pGD Touch terminals are the new line of graphic touch screen displays designed to make the interaction between man and machine simple and intuitive, making navigation easier between the various screens.



The heart of the system: pCO5+

The new CAREL programmable controller designed for multiple air-conditioning and refrigeration applications



USB CONNECTION

Direct accessibility to the controller.



EASY ADDRESS SETTING

Dedicated interface for setting the network address.

Connectivity – pCO5 Features two integrated serial interfaces, two optional expansion cards and two USB ports

USB – Simple service and monitoring using the standard USB port. USB Host port available to connect standard USB dongle and USB Device port to connect to a PC without external converters

Smart Screw Compressor R-104a by Hanbell

High-Efficiency and reliability Compressor

The screw compressor have step working for enhance cooling capacity as well as energy efficiency

High-efficiency Motor

Patented motor Cooling design in ducts of refrigerant flow encompassing stator provides best dissipation of heat

High-efficiency Screw Rotor Profile

Hyper volume efficiency and minimum clearance

High-performance integral oil Separator

Finer size of mesh, Low pressure drop and oil carry-over

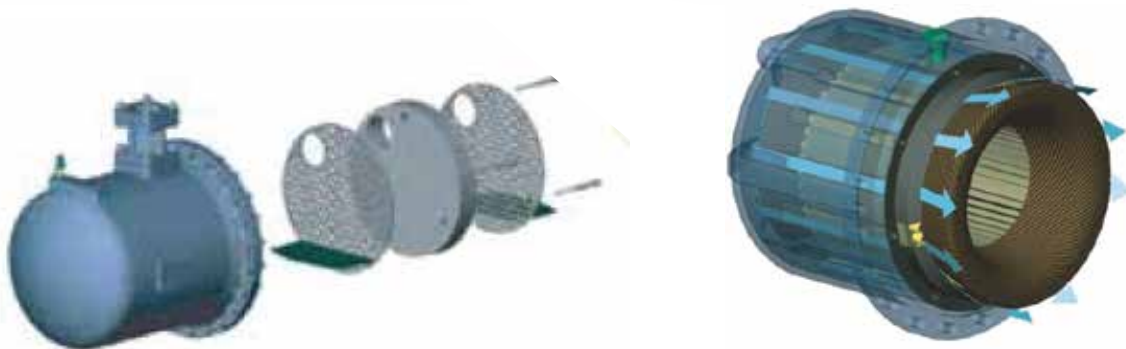

SPECIFICATION STANDARD ACCESSORIES

UNIT CASING

- Constructed of zinc coated heavy gauge, galvanized steel
- Powder coating for protection against rust

COMPRESSOR

- Hermatic screw compressor
- All compressor are mounted on vibration isolation

REFRIGERANT

- R-134a

ELECTRICAL PART

- Magnatic & Overload contractor for fan motor and compressor
- Unit Main Breaker
- PLC Controller with Touch Screen LCD Display
- Digital Hour Meter
- Phase Protection
- Pressure Transducer

REFRIGERATION PART

- Service & Shut off Valve
 - Thermostatic expansion valves
 - Sight Glasses
 - Filter Driers
 - High-Low Pressure Guage
 - Chilled Water Flow Switch
- ## HEAT EXCHANGER
- Seamless copper tubes, mechanically expanded into aluminium fins with full height collars
 - Leak tested at 350 PSIG from factory.
 - Dynamically and statically balanced Direct-drive fan
 - Shell and Tube evaporator

PHYSICAL DATA

MODEL	VACU-CHB	050	060	070	080	100	120	150	180	200	240
NOMINAL CAPACITY**	MBH.	470	592	626	737	939	1002	1356	1624	1850	2012
POWER CONSUMPTION	(kW)	44.91	54.01	58.26	67.76	89.82	95.82	124.47	150.72	169.38	187.03
COMPRESSOR	Type	Screw									
	HP	50	60	70	80	50 x 2	60 x 2	75 x 2	90 x 2	100 x 2	120 x 2
	Qty./Unit	1					2				
CONDENSER COIL	Type	Aluminium Fin with Inner Grooved Copper Tube									
	Face Area (ft ²)	78		117		156		195	234	273	312
	Rows / FPI	3 / 12	3 / 14	3 / 10	3 / 12			3 / 14			
	Tube Size (Inch)	3/8									
CONDENSER FAN & MOTOR		Propeller Fan : Vertical Discharge : Direct Drive									
	Quantity	4		6		8		10	12	14	16
	Power (HP.)	1									
	RPM	900									
	Air Quantity (CFM)	44,000		66,000		88,000		110,000	132,000	154,000	176,000
REFRIGERANT	Type	R-134a									
	Charge	Holding Charge: R-134a									
WATER CHILLER		Shell and Tube Heat Exchanger									
NO. of CIRCUIT		1					2				
	Chilled Water Flow Rate (GPM)	94	118.4	125.2	147.4	187.8	200.4	271.2	324.8	370	402.4
	Chilled Water Temp. IN/OUT (°F)	55/45									
	Chilled Water Pressure Drop (Ft. WG)	3.87	3.13	8.07	8.07	13.9	8.63	13.01	14.71	21.12	9.27
	Water Connection IN/OUT (Inch)	3		4		5		6		8	
DIMENSION											
	Length (mm.)	2,270		3,385		4,500		5,615	6,730	7,845	8,960
	Width (mm.)	2,030									
	Height (mm.)	2,200									
WEIGHT (Aprox.)	(kgs.)	1,884	1,970	2,505	2,565	3,626	3,737	4,525	5,363	6,141	6,717

Note

MBH = 1000 BTUH FOR SI. UNIT, COOLING CAPACITY (KW) = (MBH x 1000) / 3412

**Nominal Capacity Based on 45 °F Suction Temp And 95 °F Ambient Temp

ELECTRICAL DATA

MODEL	VACU-CHB	050	060	070	080	100	120	150	180	200	240
	Quantity	1					2				
COMPRESSOR (Each)	Volt / Phase / Hz	380 / 3 / 50									
	Power Input (Watt)	40,800	49,900	52,100	61,600	40,800	43,800	57,100	69,200	77,500	85,300
	FLA. (Amp.)	74.40	91.10	94.40	113.40	74.4	78.9	107.0	122.4	137.1	154.7
	LRA. (Amp.)	230	260	260	345	230	230	345	292	407	433
	Quantity	4		6		8		10	12	14	16
FAN MOTOR (Each)	Volt / Phase / Hz	380 / 3 / 50									
	Power Input (Watt)	1,027									
	FLA. (Amp.)	2.30									

Note

FLA = Full Load Amp. LRA = Locked Rotor Amp.

Specification are subjected to change without notice for future improvement.



UNIAIRE CORPORATION CO., LTD.

69 Moo 3 Kingkaew Rd.,Bangplee,Samutprakarn 10540 THAILAND Tel.+662-312-4500 Fax.+662-312-4277

http://www.uni-aire.com E-mail: export@uni-aire.com , localsale@uni-aire.com