

MODEL CAHV/H-W



CHILLED WATER AIR HANDLING UNIT

CAPACITY RANGE FROM

80,000 TO 750,000 BTU/H

(6.7 to 62.5 RT)



FEATURES

- Easy Installation & Maintenance
- High Performance & High External static
- Heavy-duty Blower
- Copper tube with Aluminium Fin Coils



Air Conditioning Experts

CAHV-008W to CAHV-010W

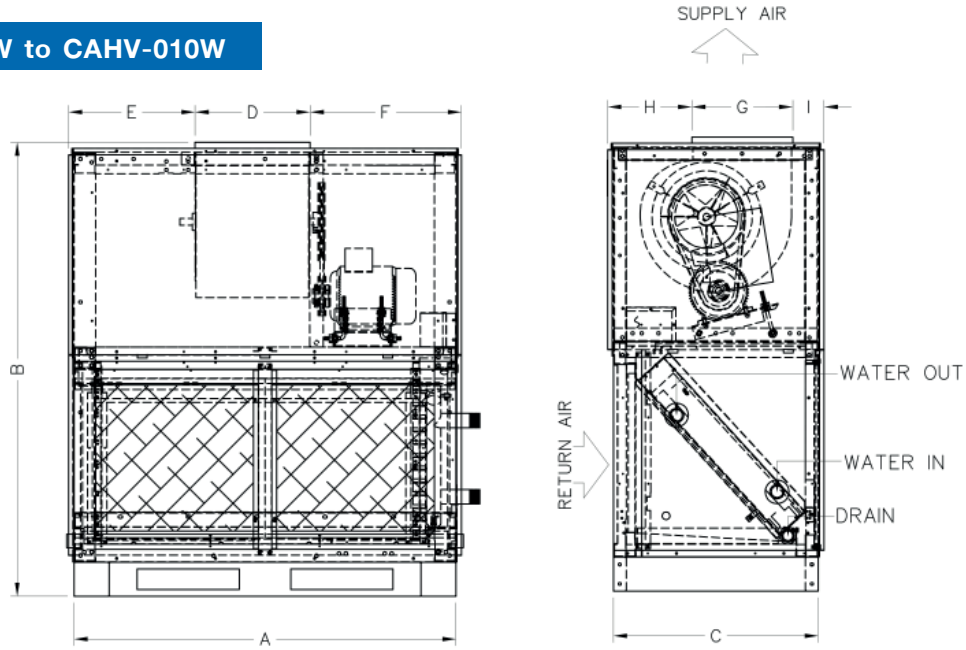

MODEL	DIMENSION (mm.)									PIPE CONNECTION (Inch)		
	A	B	C	D	E	F	G	H	I	WATER IN	WATER OUT	DRAIN
CAHV-008W	1,120	1,331	601	337	371	444	296	247	92	1-1/4	1-1/4	3/4
CAHV-009W	1,120	1,331	601	337	371	444	296	247	92	1-1/4	1-1/4	3/4
CAHV-010W	1,120	1,331	601	337	371	444	296	247	92	1-1/2	1-1/2	3/4

CAHV-012W to CAHV-075W

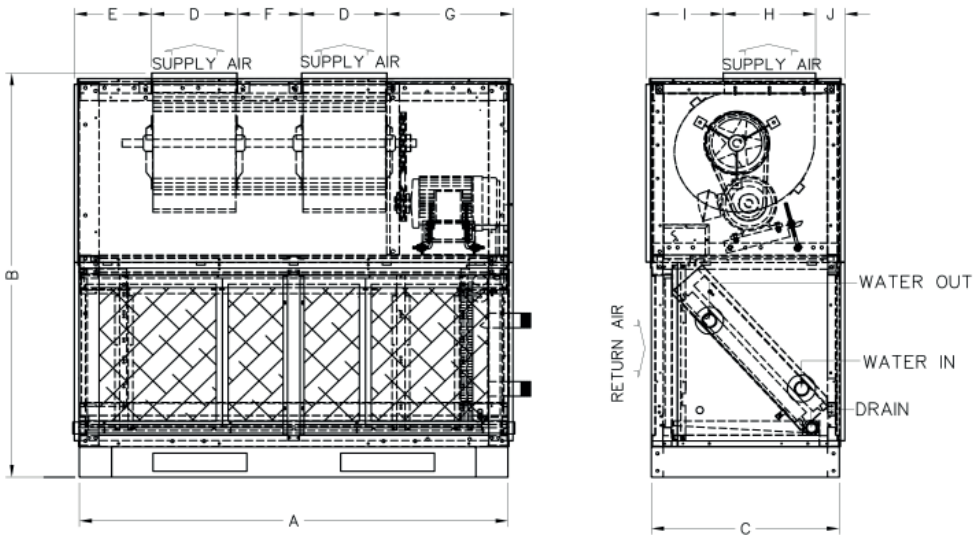

MODEL	DIMENSION (mm.)										PIPE CONNECTION (Inch)		
	A	B	C	D	E	F	G	H	I	J	WATER IN	WATER OUT	DRAIN
CAHV-012W	1,370	1,331	601	273	247	206	403	296	246	93	1-1/2	1-1/2	1
CAHV-015W	1,570	1,331	601	337	238	256	434	296	246	93	2	2	1
CAHV-020W	1,998	1,661	712	403	398.5	316	509.5	349	304.5	88.5	2-1/2	2-1/2	1-1/4
CAHV-025W	1,998	1,661	712	403	398.5	316	509.5	349	304.5	88.5	2-1/2	2-1/2	1-1/4
CAHV-030W	1,998	1,876	770	477	183.5	381	511.5	408	305.5	88.5	3	3	1-1/4
CAHV-040W	2,270	2,121	870	480	393	375	574	413	403	88	3	3	1-1/4
CAHV-050W	2,420	2,328	1,079	440	522	333	633	488	264	237	3	3	1-1/4
CAHV-060W	2,820	2,328	1,079	566	457	449	786	488	260	241	3	3	1-1/4
CAHV-075W	3,227	2,500	1,079	575	819	442	819	575	250	164	4	4	1-1/4

CAHH-008W to CAHH-010W

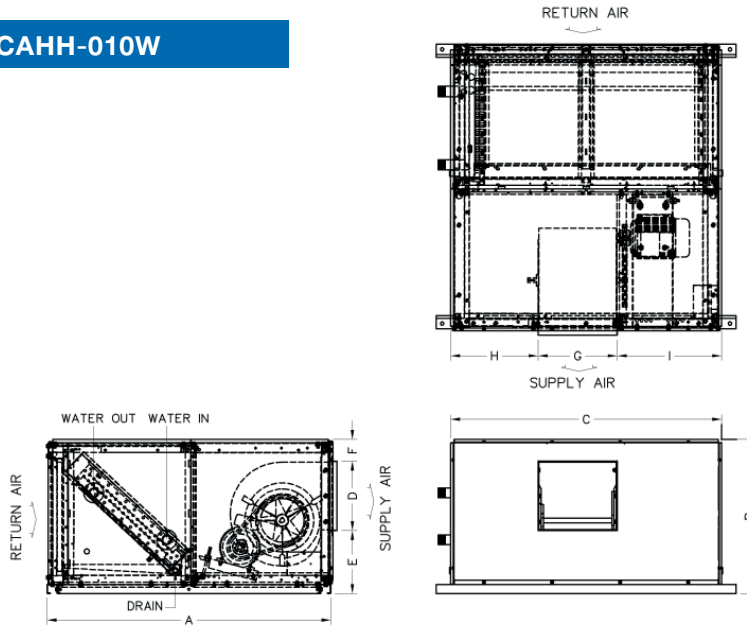

MODEL	DIMENSION (mm.)									PIPE CONNECTION (Inch)		
	A	B	C	D	E	F	G	H	I	WATER IN	WATER OUT	DRAIN
CAHH-008W	1,208	656	1,154	296	268	92	337	372	445	1-1/4	1-1/4	3/4
CAHH-009W	1,208	656	1,154	296	268	92	337	372	445	1-1/4	1-1/4	3/4
CAHH-010W	1,208	656	1,154	347	245	65	401	308	445	1-1/2	1-1/2	3/4

CAHH-012W to CAHH-075W

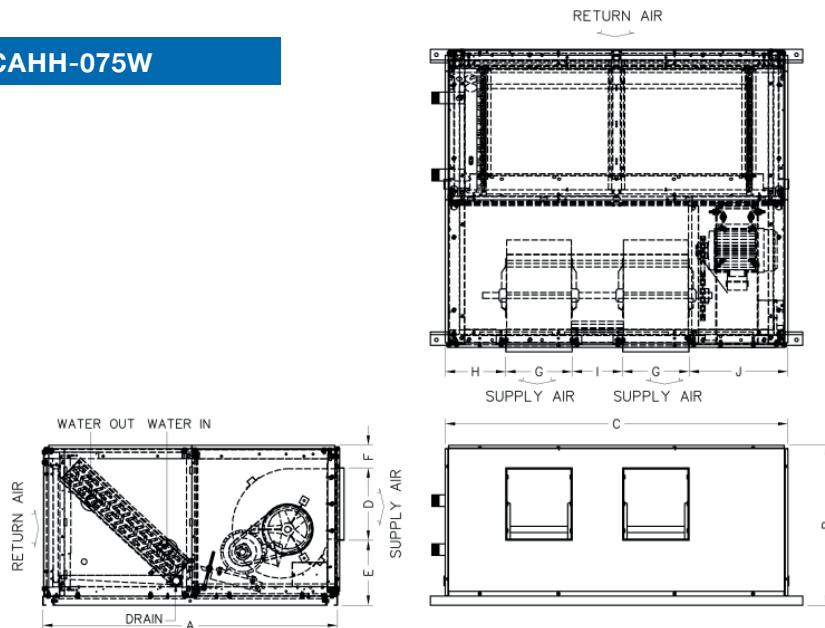

MODEL	DIMENSION (mm.)										PIPE CONNECTION (Inch)		
	A	B	C	D	E	F	G	H	I	J	WATER IN	WATER OUT	DRAIN
CAHH-012W	1,208	656	1,404	296	268	93	273	248	206	404	1-1/2	1-1/2	1
CAHH-015W	1,208	656	1,604	296	268	93	337	239	256	435	2	2	1
CAHH-020W	1,536	772	2,032	349	334.50	88.50	403	399.5	316	510.5	2-1/2	2-1/2	1-1/4
CAHH-025W	1,536	772	2,032	349	334.50	88.50	403	399.5	316	510.5	2-1/2	2-1/2	1-1/4
CAHH-030W	1,746	832	2,030	413	332.0	87	480.0	182	378.0	510.0	3	3	1-1/4
CAHH-040W	1,991	933	2,304	413	432	88	480	392	375	575	3	3	1-1/4
CAHH-050W	2,208	1,260	2,368	485	465	310	444	521	329	630	3	3	1-1/4
CAHH-060W	2,210	1,260	2,820	487	458.5	314.5	566	392.5	449	846.5	3	3	1-1/4
CAHH-075W	2,453.5	1,260	3,310	575	447.5	237.5	575	858.5	443	858.5	4	4	1-1/4

Cooling Coil (Chilled Water)

- Constructed of copper tube with corrugated aluminium fin
- High heat transfer surface
- Leak tested at 250 psig

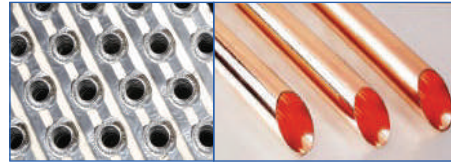

Casing

A sturdy, electro-zinc coated steels sheet cabinet is provided in modern SLIM design. All members of the cabinet are die formed that assures a good dimensional and quality control. Cabinet are finished in HARMONY BEIGE color of ELECTROSTATIC POWDER painting process that provides a double protection against rust.

SPECIFICATION MODEL : CAHV/H (CHILLED WATER COIL)																									
MODEL	CAHV/H	008W	009W	010W	012W	015W	020W	025W	030W	040W	050W	060W	075W												
Nominal Cooling Capacity	(BTU/Hr)	80,000	90,000	100,000	120,000	150,000	200,000	250,000	300,000	400,000	500,000	600,000	750,000												
	(RT)	6.7	7.5	8.3	10.0	12.5	16.7	20.8	25.0	33.3	41.7	50.0	62.5												
Power Supply	(Volt/Phase/Hz)	380/3/50																							
Air Flow Rated (Nominal)	(CFM)	1,950	2,500	2,950	3,300	4,250	6,500	7,000	8,000	10,500	13,400	16,000	20,000												
Air Flow Rated (Range)	(CFM)	1,450-2,450	2,000-3,000	2,450-3,450	2,800-3,800	3,250-5,250	5,000-8,000	5,000-9,000	6,000-10,000	8,500-12,500	10,400-16,400	12,000-20,000	17,000-23,000												
External Static Pressure (ESP.)	(in.wg.)	0.21	0.22	0.22	0.23	0.24	0.37	0.56	0.65	0.75	0.98	1.13	1.15												
Cooling Coil	Material	Aluminium Louver Fin With Copper Tube (Plain Tube)(OD 3/8")						Aluminium Corrugated Fin With Copper Tube (Plain Tube)(OD 1/2")																	
	Face Area	5.50		6.00		7.00		9.00		14.27		16.65		21.25		26.25		31.56		40.63					
	Row...FIN	4...12		4...14				3...14		4...14															
	Water Flow Rate	16.0		18.0		20.0		24.0		30.0		40.0		50.0		60.0		80.0		100.0		120.0		150.0	
	Water Pressure Drop	9.99		10.54		12.65		8.84		5.22		7.42		9.91		9.59		6.01		7.89		12.96		14.31	
Blower Set	Type	Centrifugal (Vertical or Horizontal Discharge) (Belt Drive)																							
	Blower Quantity	1				2																			
	Motor Quantity	1																							
	Power Output	1.0		2.0				3.0		4.0		5.5		7.5		10.0		15.0							
	Rated Current	1.95		3.40				4.87		6.50		8.67		11.10		15.30		21.46							
Control Type	Optional																								
Air Filter Type	Aluminium Filter																								
Weight	(kgs.)	131	146	161	186	240	260	305	365	415	470	500													

*Nominal capacity based on : Entering Air temp. 80° F db /67° F wb
Chilled water temp inlet/outlet 45/55° F

ALTERNATE BLOWER ARRANGEMENTS

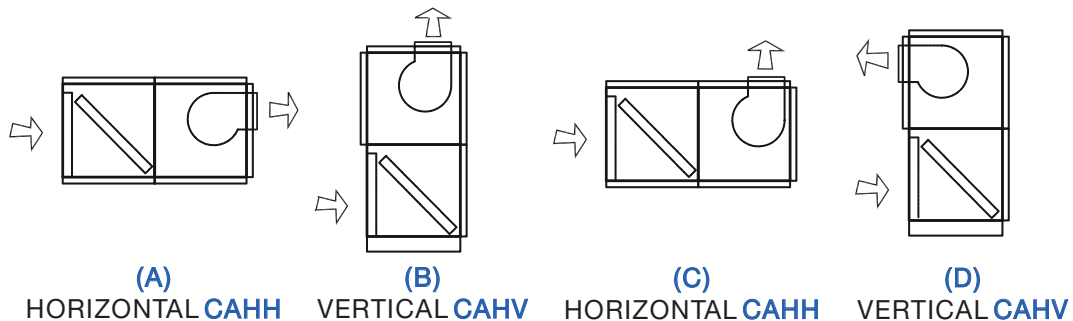

“Orders without specific blower arrangement will be considered as standard configuration (A or B)”



UNIAIRE CORPORATION CO., LTD.

69 Moo 3 Kingkeaw Rd., Rachatewa District, Banglee, Samutprakarn 10540 Thailand

Tel : +662-312-4500, Website : www.uni-aire.com

Export Sale : export@uni-aire.com

Domestic Sale : localsale@uni-aire.com