

# MODEL AHE-H / AKQ

FOR DIRECT EXPANSION SYSTEM

DUCTED TYPE

CAPACITY FROM

30,000 TO 60,000 BTUH

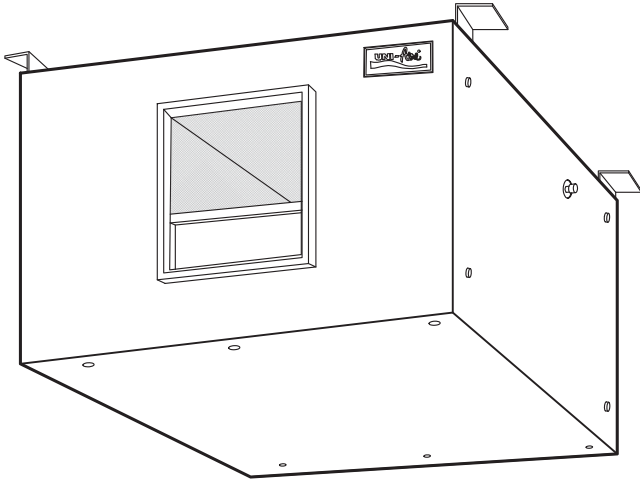

AHEH (Horizontal)

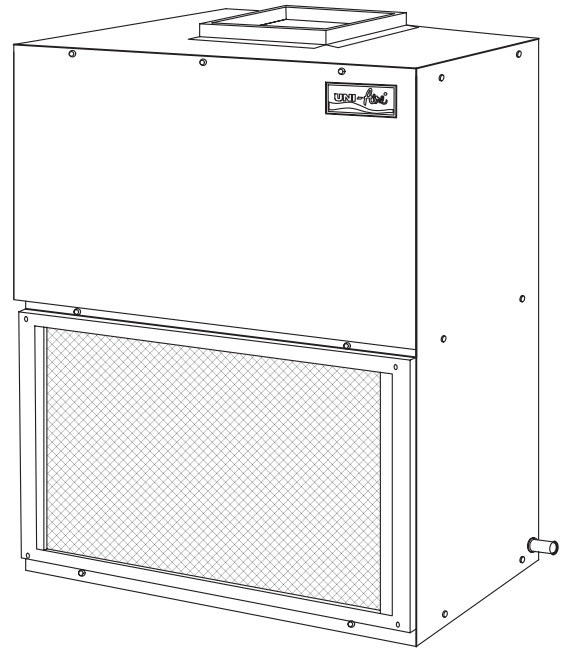

AHE (Vertical)

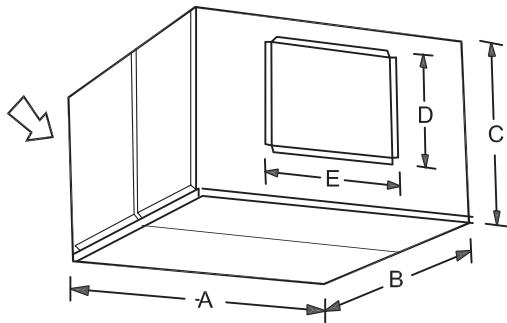

MODEL AHEH

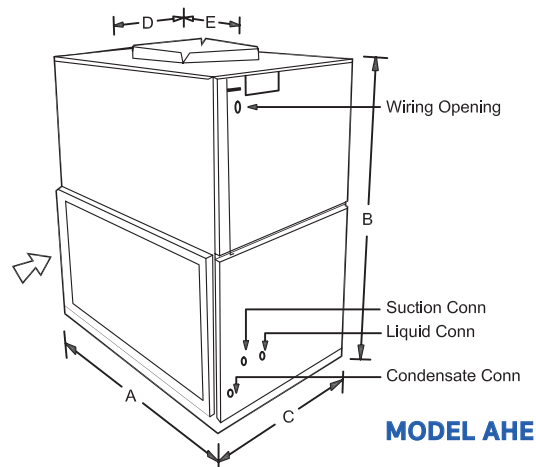

MODEL AHE

MODEL	A	B	C	D	E
AHE/H-30	737	890	474	273	257
AHE/H-36	737	890	474	273	257
AHE/H-40	922	890	474	273	314
AHE/H-50	922	890	474	273	314
AHE/H-60	922	890	474	292	353



Air Conditioning Experts



**THERMOSTAT**



Digital wired thermostat (Option)



Wired digital remote controller WIFI (Option)



Wireless digital thermostat (Option)

**CONDENSING UNIT MODEL : AKQ (FIBER GLASS)**



**Auto Restart**  
Air conditioning system turns on automatically after electricity supply returns from a power failure. the system also memorizes every setting before the outage.

**3 Minute Time Delay**  
Prevent damage to the compressor from voltage sag or power failure.

**4 Speed Motor** 4 speeds adjustable wind blow Turbo-High-Medium-Low For Turbo cool or Quiet cool.

**Turbo Fan** Powerful turbo motor delivers coolness to the room quickly yet quietly.

**PHYSICAL DATA & ELECTRICAL DATA**

SPECIFICATION MODEL : AHE, AHEH / AKQ							
Nominal Cooling Capacity (BTU/Hr)		30,000	36,000	36,000	40,000	50,000	60,000
SEER (BTU/Hr / Watt)		11.05	11.05	11.05	11.05	11.56	11.05
COP (Watt / Watt)		3.05	3.05	3.05	3.05	3.19	3.05
Power Consumption (Watt)		2,820	3,475	3,475	3,869	4,605	5,775
Rated Operation Current (Amp.)		12.20	15.00	5.90	6.60	8.03	10.25
Power Supply (Volt/Phase/Hz)		220/1/50			380/3/50		
TIS Standard (มาตรฐาน มอก. 2134-2553)						-	-
TIS Standard (มาตรฐาน มอก. 1529-2561)							
Fan Coil Unit	Model : AHE, AHEH	AHE, AHEH-30F	AHE, AHEH36F	AHE, AHEH-36F	AHE, AHEH-40F	AHE, AHEH-50F	AHE, AHEH-60F
	Type	Ducted Type					
Rated Air Flow at High Speed (CFM)		1,000	1,200	1,200	1,400	1,600	2,000
Fan Type		Centrifugal (Direct Drive)					
Evaporator Coil Type		Louver Aluminium Fin with Copper Tube					
Expansion Device Type		Capillary Tube					
Control Type		Option					
Air Filter Type		Aluminium Filter					
Drain Connection (Inch)(OD)		3/4					
AHE : Dimension (W x D x H) (mm.)		740 x 478 x 917			924 x 478 x 917		
AHE : Weight (kgs.)		52	54	75	77		
AHEH : Dimension (W x D x H) (mm.)		740 x 938 x 478			924 x 938 x 478		
AHEH : Weight (kgs.)		52	54	75	78		
Condensing Unit	Model : AKQ	AKQ-301FB	AKQ-361FB	AKQ-363FB	AKQ-403FB	AKQ-503FX	AKQ-603FX
	Type	Horizontal Air Flow					
Fan Type		Propeller Fan					
Condenser Coil Type		Louver Aluminium Fin with Copper tube					
Compressor Type		Rotary			Scroll		
Refrigerant Type		R-32 (Holding Charge)					
Pipe Connection	Suction Line (Inch)(OD)	3/4					
	Liquid Line (Inch)(OD)	3/8			1/2		
Dimension (W x D x H) (mm.)		835 x 594 x 710			835 x 594 x 812		
Weight (kgs.)		63	70	82	102		

Cooling capacity based on 27 °C DB, 19 °C WB air on evaporator coil and 35 °C DB air on condenser.

Specifications are subjected to change without notice for future improvement.



**UNIAIRE CORPORATION CO., LTD.**

69 Moo 3 Kingkeaw Rd., Rachatewa District, Bangplee, Samutprakarn 10540 Thailand

Tel.+662-312-4500, Email.export@uni-aire.com  
www.uni-aire.com    Whatsapp.+666-2312-3069