



MODEL AHE/AHEH-W

LOW STATIC (75 Pa External Static)

CHILLED WATER FAN COIL UNIT

DUCT TYPE

HIGH STATIC (75 Pa External Static)

CAPACITY RANGE FROM

30,000 TO 60,000 BTU/H (8.79 kW -17.58kW)

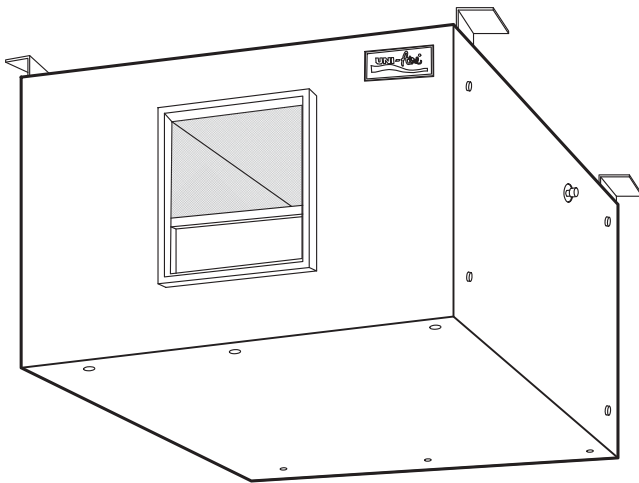

AHEH (Horizontal)

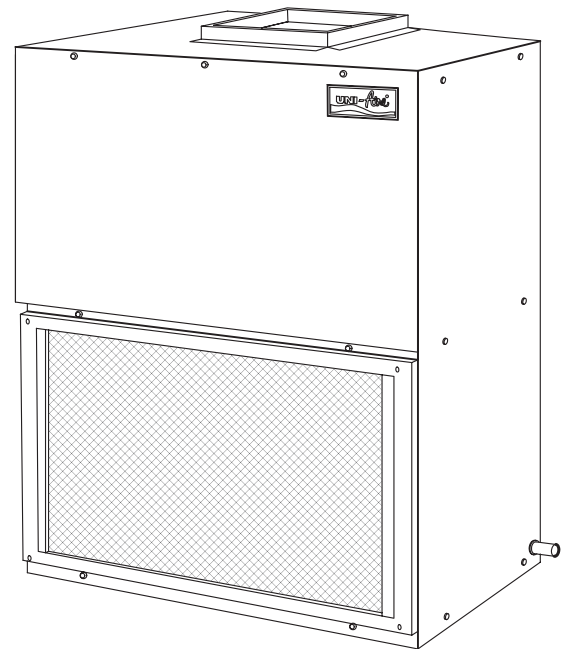

AHE (Vertical)

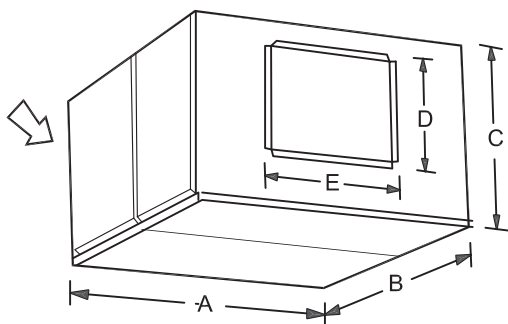

MODEL : AHEH

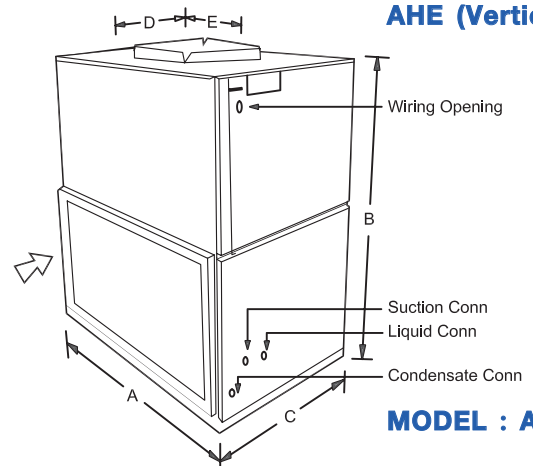

MODEL : AHE



Air Conditioning Experts

(Recommend : Don't use long duct)

Cooling Coil (Chilled Water)

- Corrugated aluminium fin coil Improves heat exchange efficiency
- Plain copper tube Prevent scale build-up in the pipe surface
- Leak tested at 250 psig

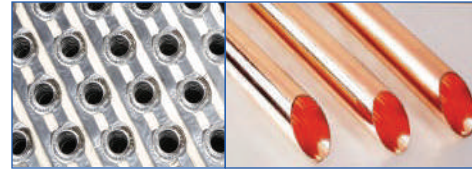

Casing

A sturdy, electro-zinc coated steel sheet cabinet is provided in modern SLIM design. All members of the cabinet are die formed that assures a good dimensional and quality control. Cabinet are finished in HARMONY BEIGE color of ELECTROSTATIC POWDER painting process that provides a double protection against rust.

Thermostat



Digital wired thermostat (Option)



Wired digital thermostat WIFI (Option)



Wireless digital thermostat (Option)



2 Speed Motor 2 speeds adjustable wind blow High-Low For Turbo cool or Quiet cool.



Turbo Fan Powerful turbo motor delivers coolness to the room quickly yet quietly.

SPECIFICATION MODEL : AHE/AHEH (CHILLED WATER COIL)							
MODEL			AHE/H-30W	AHE/H-36W	AHE/H-40W	AHE/H-50W	AHE/H-60W
Nominal Cooling Capacity*	(BTU/Hr)		30,000	36,000	40,000	50,000	60,000
	(RT)		2.5	3.0	3.3	4.2	5.0
Power Supply	(Volt/Phase/Hz)		220/1/50				
Air Flow Rated at High Speed	(CFM)		1,000	1,200	1,400	1,600	2,000
Cooling Coil	Material		Aluminium Corrugated Fin With Copper Tube (Plain Tube)(OD 3/8")				
	Face Area	(SQ.FT.)	2.50	3.19	4.03	4.03	4.03
	Row/FIN		3/14	3/14	3/12	3/14	4/12
	Water Flow Rate	(GPM)	6.0	7.2	8.0	10.0	12.0
	Water Pressure Drop	(FT.WG.)	6.72	10.77	9.21	13.53	11.27
Fan Set	Type		Centrifugal (Direct Drive)				
	Blower Quantity	(PCS.)	1				
	Motor Quantity	(PCS.)	1				
	Motor Power Output	(Watt)	139		196		282
	Rated Current	(Amp.)	0.98		1.45		2.00
Control Type			Optional				
Air Filter Type			Aluminium Filter				
Pipe Connection	Water Inlet	(Inch)(BSP)	3/4			7/8	
	Water Outlet	(Inch)(BSP)	3/4			7/8	
	Drain Pipe	(Inch)(OD)	3/4				
Dimension : AHE	Width	(mm.)	740			924	
	Depth	(mm.)	478			478	
	Height	(mm.)	917			917	
Dimension : AHEH	Width	(mm.)	740			924	
	Depth	(mm.)	938			938	
	Height	(mm.)	478			478	
Weight	(kgs.)	68	72	75	77	95	

*Nominal capacity based on : Entering Air temp. 80° F db /67° F wb

Chilled water temp inlet/outlet 45/55° F

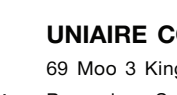

UNIAIRE CORPORATION CO., LTD.

69 Moo 3 Kingkeaw Rd., Rachatewa District,

Bangplee, Samutprakarn 10540 Thailand

Tel : +662-312-4500, Website : www.uni-aire.com

Export Sale : export@uni-aire.com

Domestic Sale : localsale@uni-aire.com

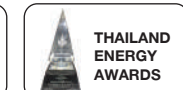

DIMENSIONAL DRAWINGS MODEL : AHE/AHEH (CHILLED WATER COIL)

AHE-30W to AHE-60W

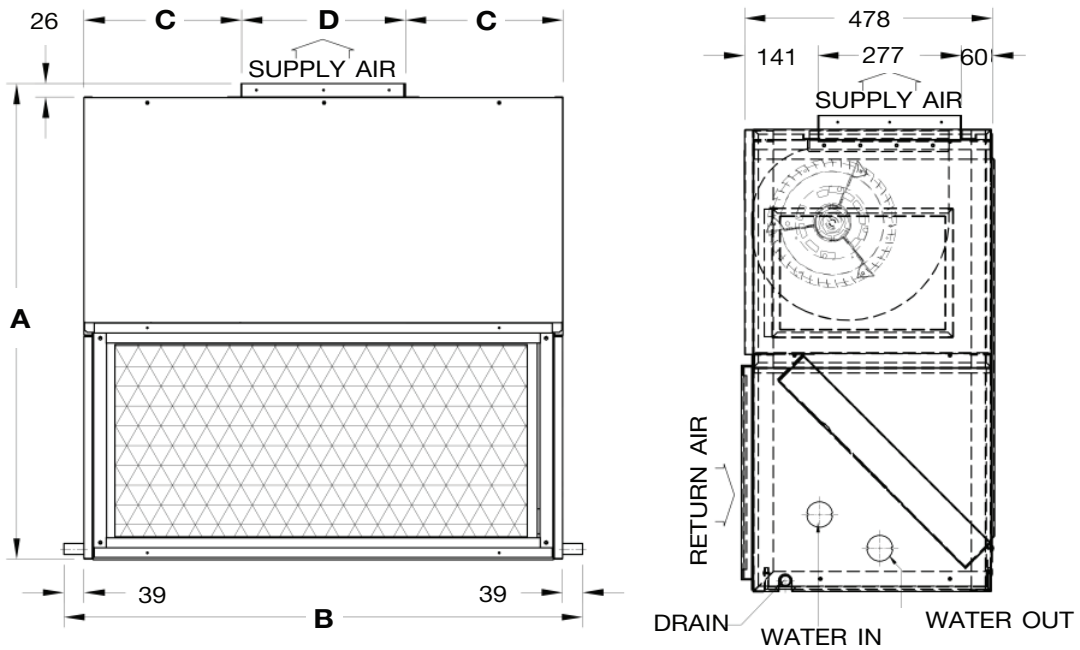

Dimension Model : AHE-W					
Model	A	B	C	D	WATER IN/OUT
AHE-30W	917	818	240	260	3/4"
AHE-36W	917	818	240	260	3/4"
AHE-40W	917	1,002	304	316	7/8"
AHE-50W	917	1,002	304	316	7/8"
AHE-60W	917	1,002	304	316	7/8"

DIMENSION : millimeters (mm.)

AHEH-30W to AHEH-60W

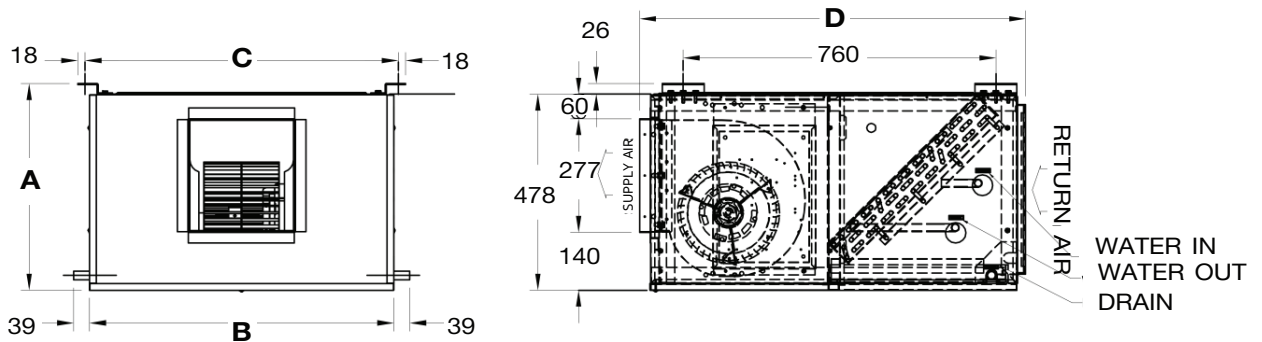

Dimension Model : AHEH-W					
Model	A	B	C	D	WATER IN/OUT
AHEH-30W	504	740	761	938	3/4"
AHEH-36W	504	740	761	938	3/4"
AHEH-40W	504	924	945	938	7/8"
AHEH-50W	504	924	945	938	7/8"
AHEH-60W	504	924	945	938	7/8"

DIMENSION : millimeters (mm.)