

MODEL SAHH / TACU

AIR HANDLING UNIT

AIR QUANTITY

FROM 2,600 TO 26,600 CFM.

COOLING CAPACITY

FROM 80,000 TO 800,000 BTUH



Air Conditioning Experts



Features

- **Compact Size:** Small footprint requires minimal installation space
- **Easy to Install:** Terminal block is located outside for easier wiring connection
- **Low Leak Construction:** The unit is designed as a single modular construction to minimize leakage, unlike multi-modular designs.
- **Easy Maintenance Filter:** Filter is located outside the casing for easier removal and cleaning

DIMENSIONAL DRAWINGS MODEL : SAHH-008A1 to SAHH-010A1

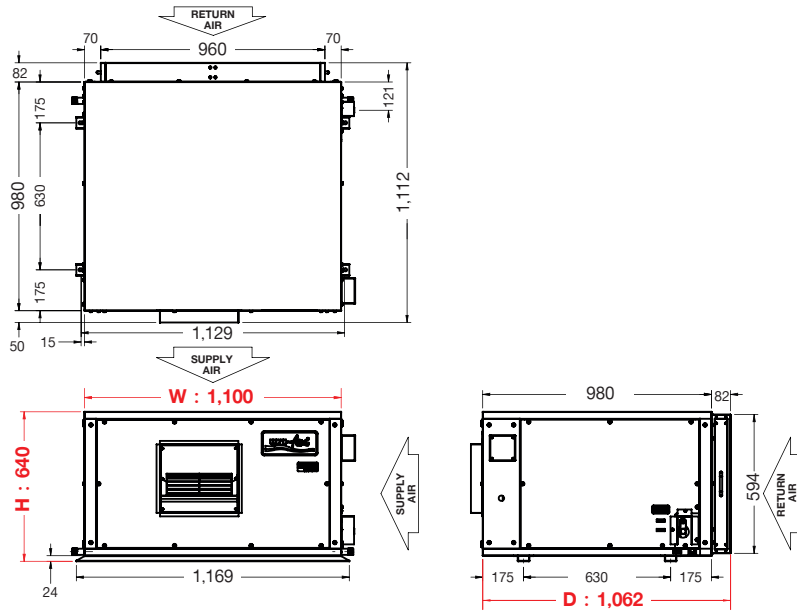

MODEL : SAHH-008A1

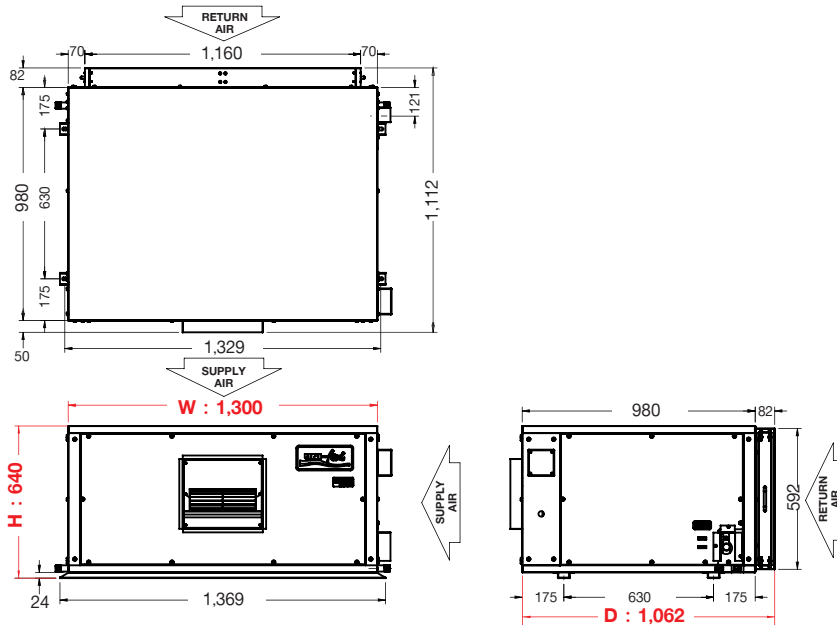

MODEL : SAHH-009A1

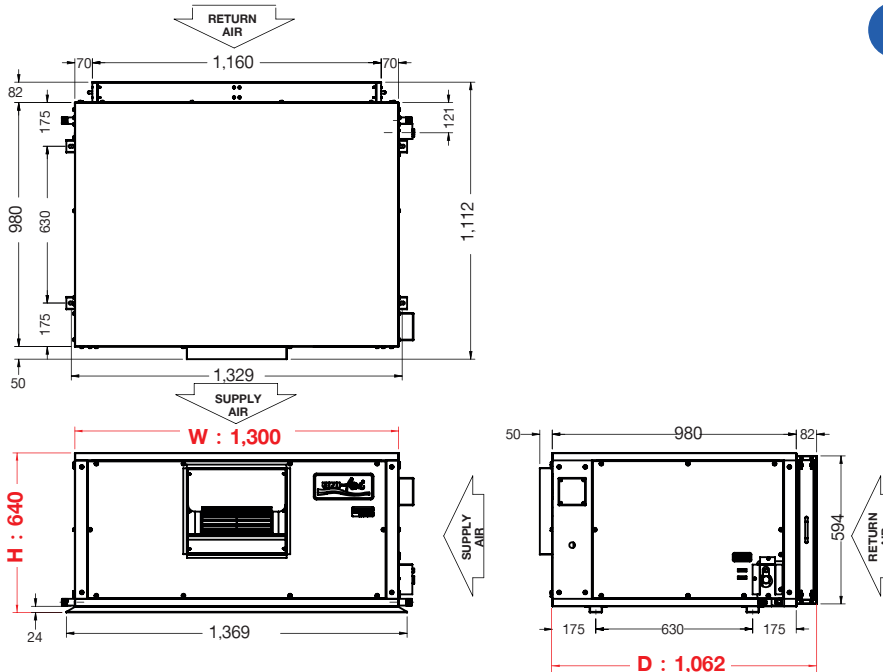

MODEL : SAHH-010A1

DIMENSIONAL DRAWINGS MODEL : SAHH-012A1 to SAHH-015A1

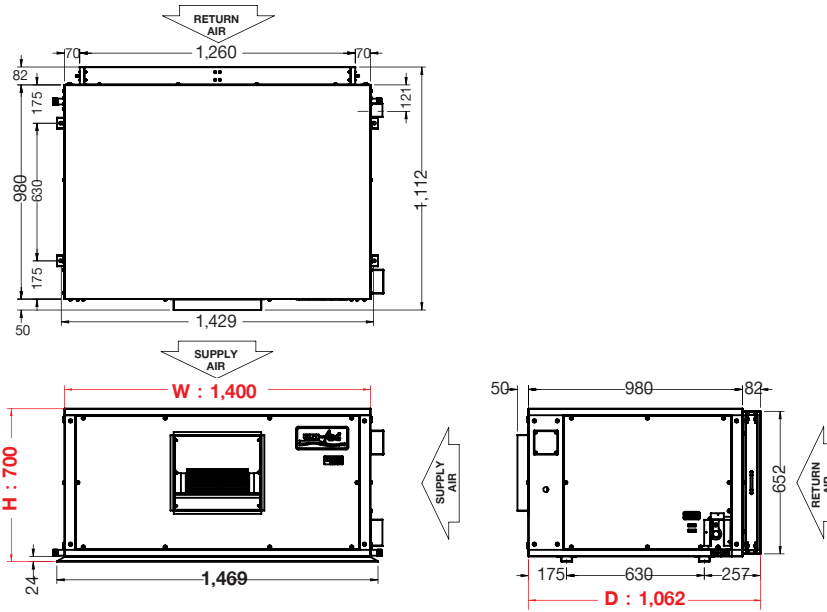

MODEL : SAHH-012A1

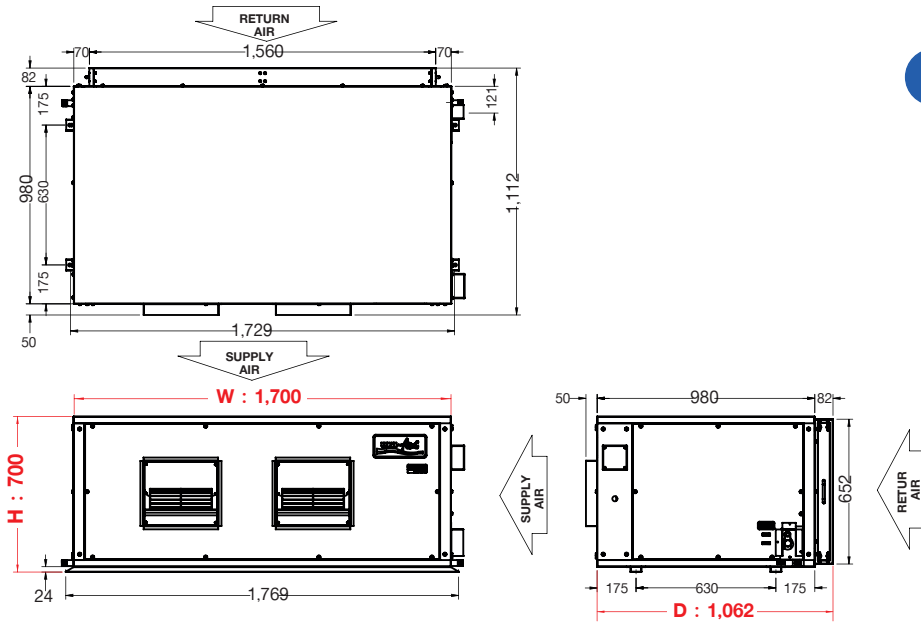

MODEL : SAHH-015A1

DIMENSIONAL DRAWINGS MODEL : SAHH-020A1 to SAHH-030A1-2C

**MODEL : SAHH-020A1 to
MODEL : SAHH-020A1-2C**

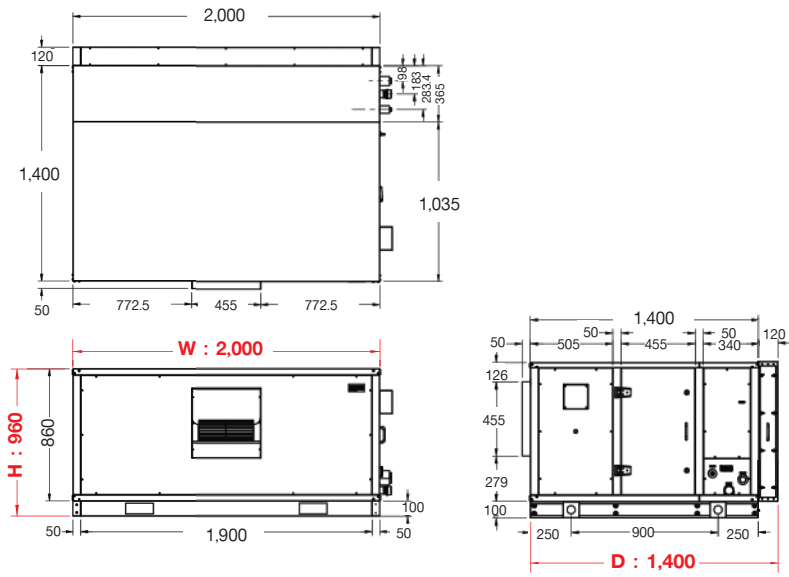

**MODEL : SAHH-025A1 to
MODEL : SAHH-025A1-2C**

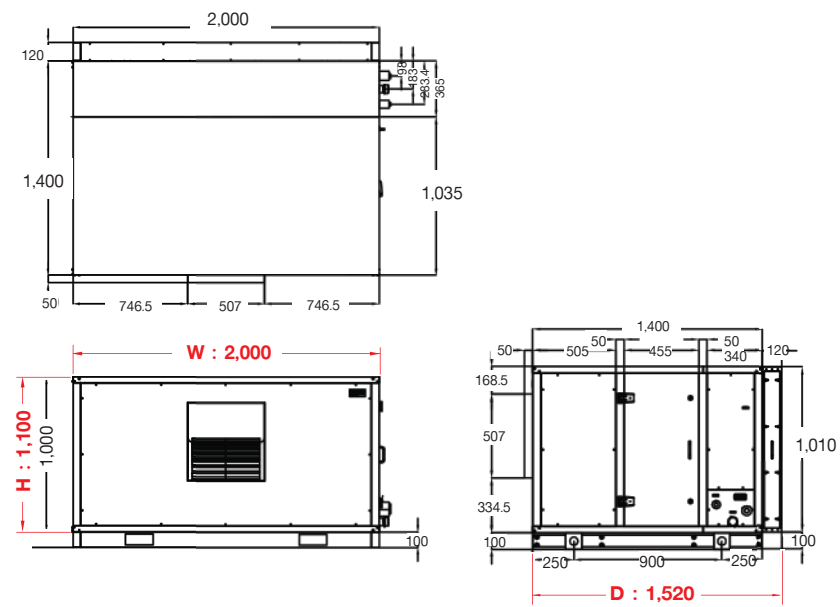

MODEL : SAHH-030A1-2C

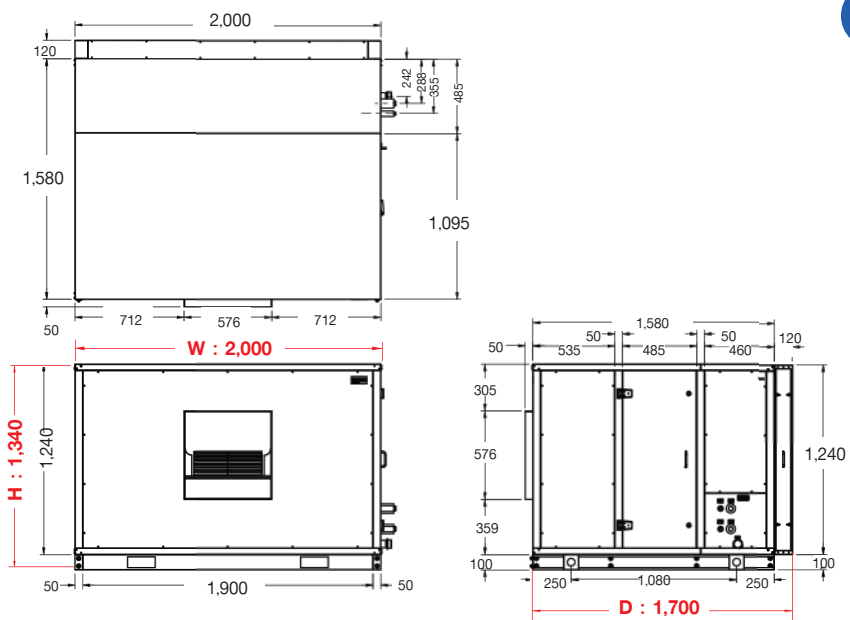

MODEL : SAHH-070A1-2C

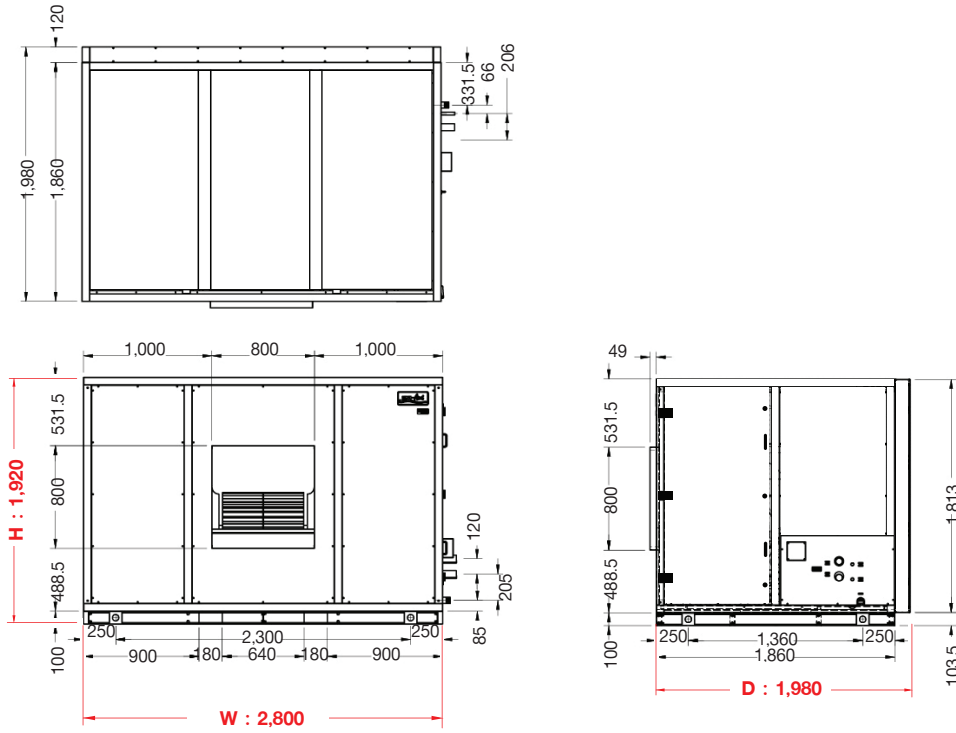

MODEL : SAHH-080A1-2C

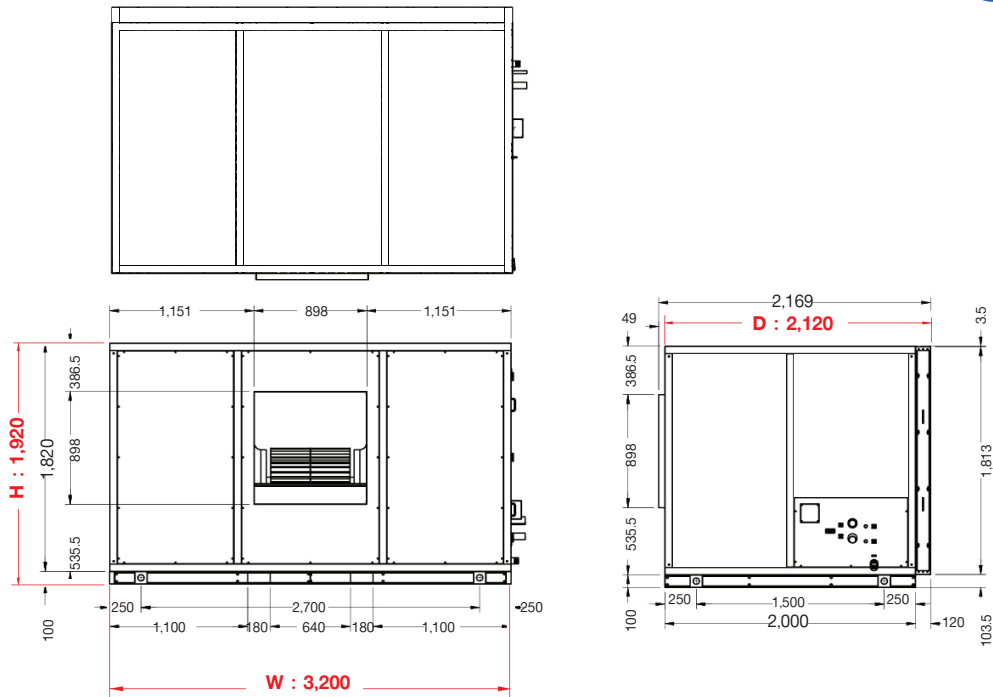

DIMENSIONAL DRAWINGS CONDENSING UNIT MODEL : TACU 008AS to TACU-030AS-2C

MODEL : TACU-008AS to TACU-010AS

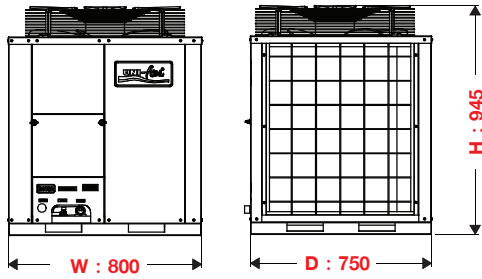

MODEL : TACU-012AS to TACU-015AS

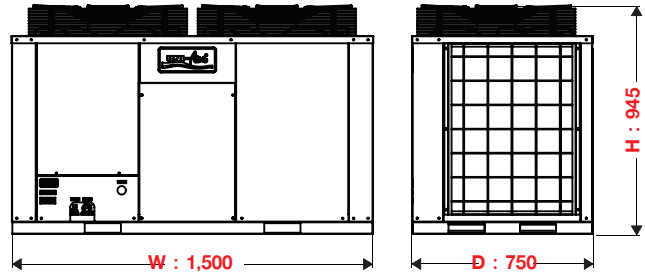

MODEL : TACU-020AS to TACU-020AS-2C

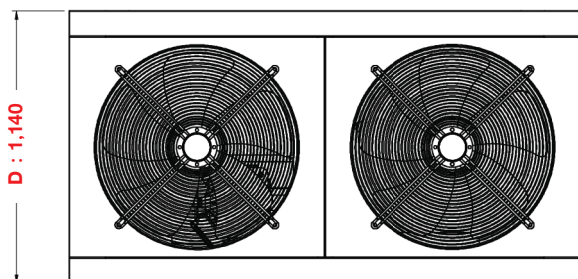
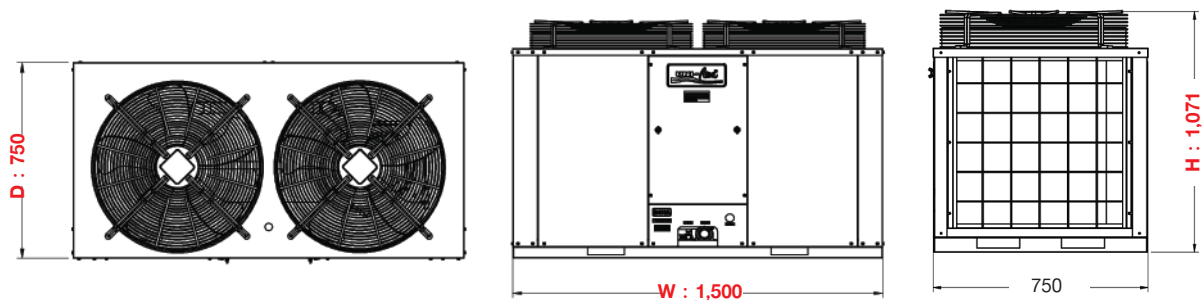

MODEL : TACU-025AS to TACU-030AS-2C

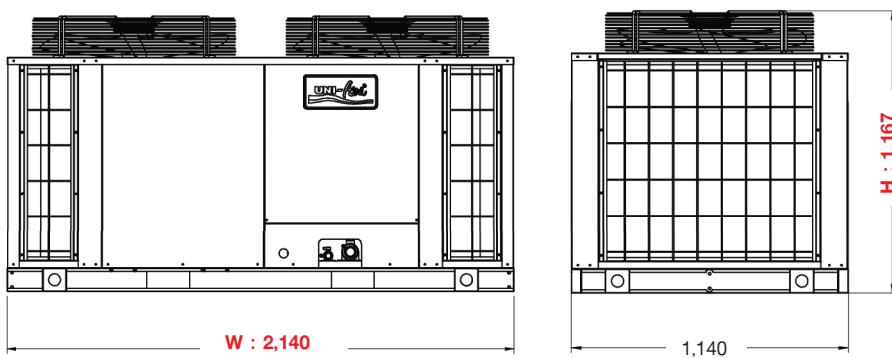

DIMENSIONAL DRAWINGS CONDENSING UNIT MODEL : TACU 040AS-2C to TACU-050A-2C

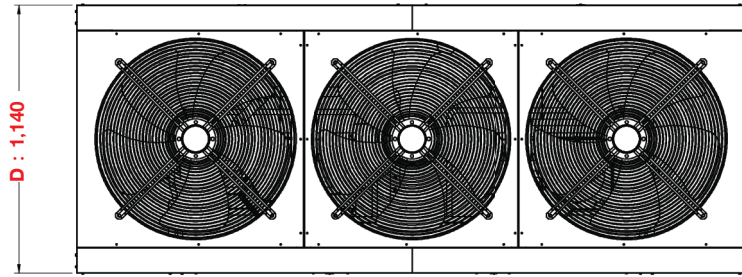

MODEL : TACU-040AS-2C

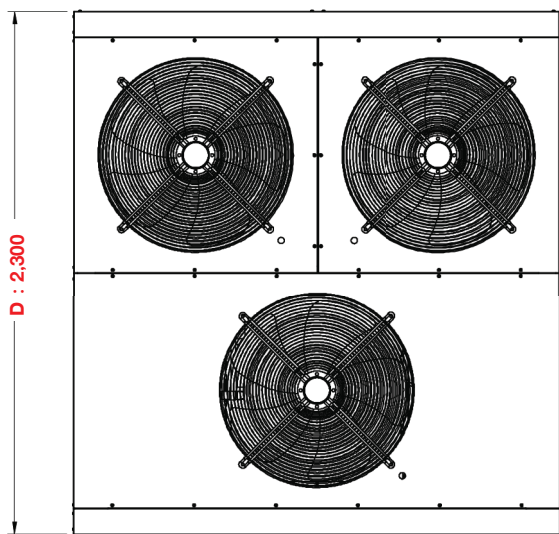
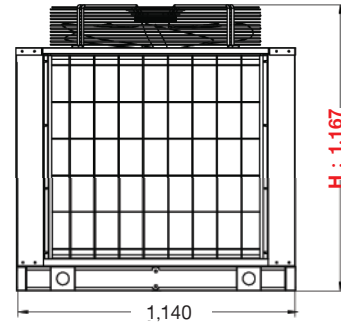
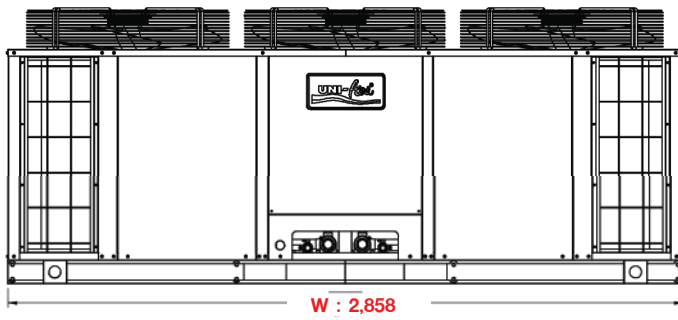

MODEL : TACU-050A-2C

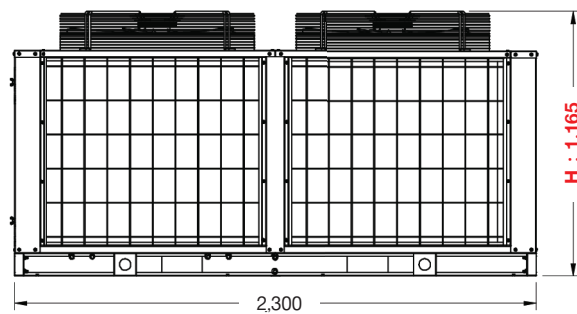
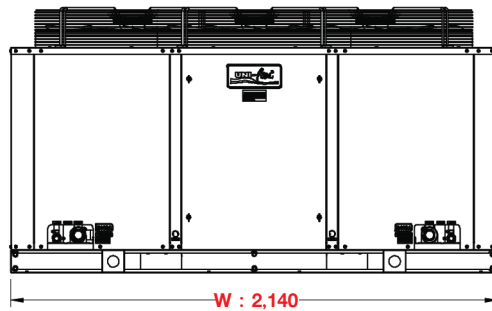

DIMENSIONAL DRAWINGS CONDENSING UNIT MODEL : TACU 060A-2C to TACU-070A-2C

MODEL : TACU-060A-2C

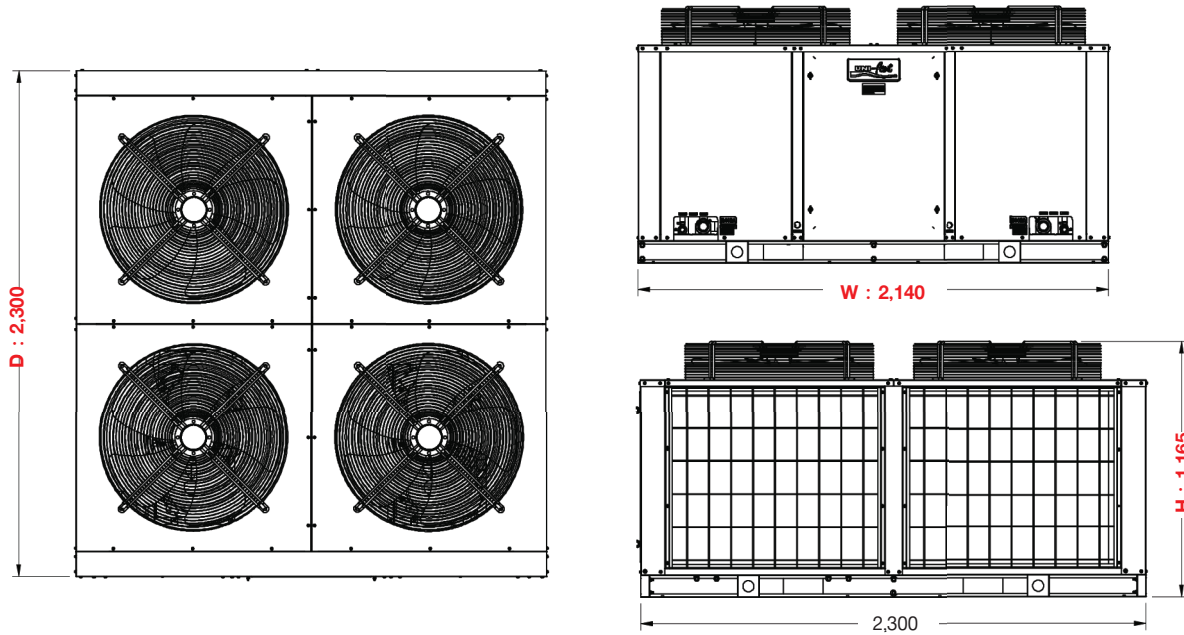

MODEL : TACU-070A-2C

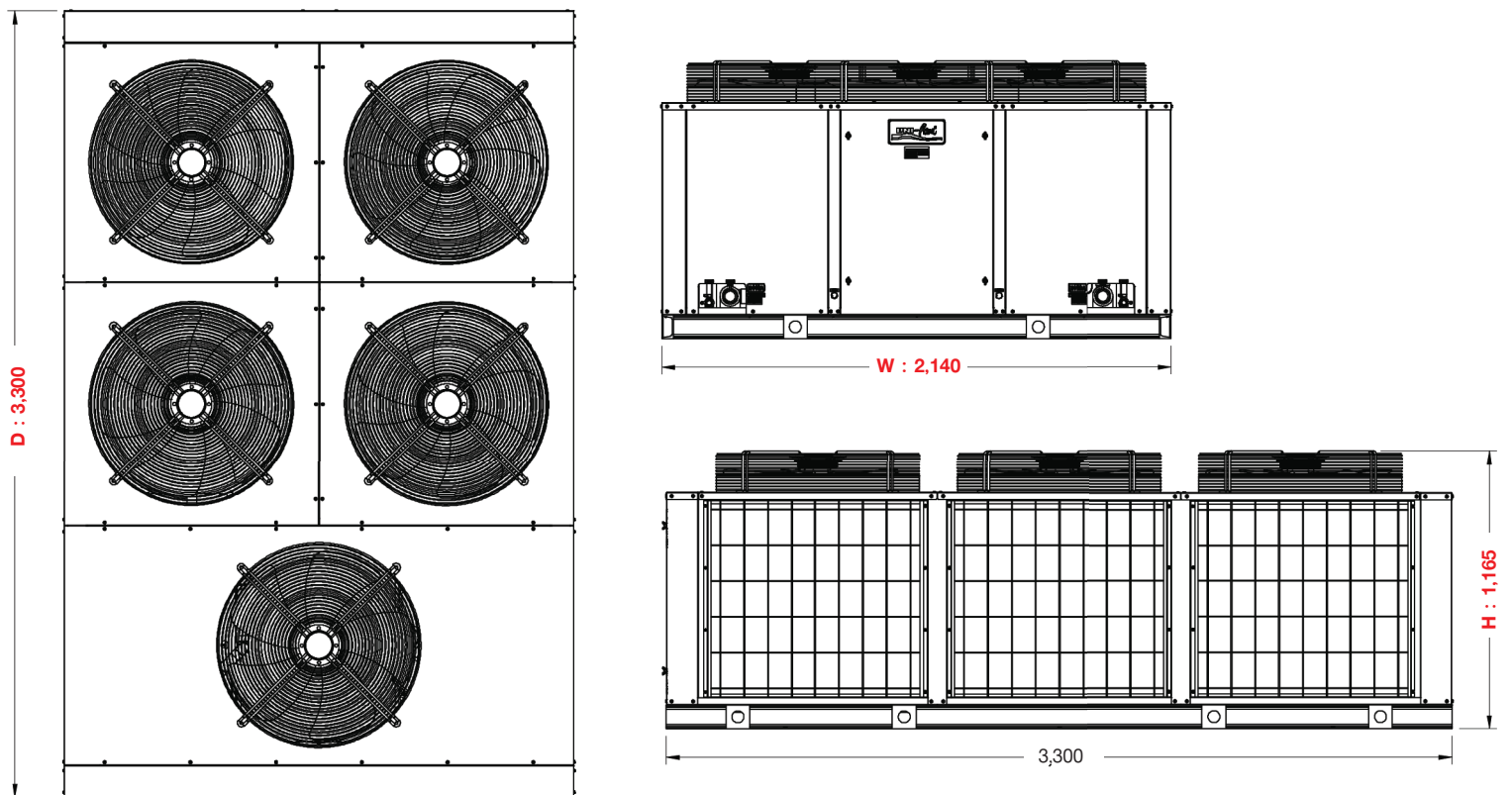

DIMENSIONAL DRAWINGS CONDENSING UNIT MODEL : TACU-080A-2C

MODEL : TACU-080A-2C

